

88 - ACR

AUDIO CASSETTE INTERFACE

DOCUMENTATION

CONTENTS:

Introduction
SIO B Board Documentation
Modem Board Assembly Procedure
Modem Board Theory of Operation
Modem Board Schematic
Using the 88-ACR
Test Programs
Test Data

© MITS, Inc., 1975

PRINTED IN U.S.A.

MITTS

"Creative Electronics"

P.O. BOX 8636
ALBUQUERQUE, NEW MEXICO 87108

The 88-ACR consists of two separate PC boards mated to each other to form a single unit. One of these is the ACR Modem Board and the other is the 88-SIO B, Serial TTL level I/O Board. The Modem board is used to key the signals into the correct audio tones and back, while the SIO B board is used to interface with the computer itself.

The first step in constructing the 88-ACR is assembling the SIO B Board. The following section is the standard SIO B Board documentation. Follow the Assembly Procedure and any pertaining errata according to the text, with the following exceptions:

PAGE 5---Resistor R1, listed as a 130-ohm resistor, should be substituted with a 47-ohm, yellow-violet-black, 1/2 Watt resistor for operation with the 88-ACR

PAGE 10-->The BAUD rate should be set at 300 maximum

✓ The jumpers POE, NDB1, NDB2 & NPB should go to +V and NSB should go to GND for 8-bit transmission

DO NOT PROCEED BEYOND THE INSTALLATION OF THE UART (IC M) ON PAGE 14, AT THIS POINT TURN TO THE ASSEMBLY PROCEDURE FOR THE MODEM BOARD.

88-ACR

BAG 1

2	uA741	101056
1	XR210	101062
1	74L02	101072
1	74L20	101039
1	7493	101030
2	93L16	101093

BAG 2

1	100 ohm 1/2w	101924
2	470 ohm 1/2w	101927
2	1K ohm 1/2w	101928
2	1.5K ohm 1/2w	101946
2	2.2K ohm 1/2w	101945
1	3.3K ohm 1/2w	102085
6	4.7K ohm 1/2w	101930
1	8.2K ohm 1/2w	102090
6	10K ohm 1/2w	101932
1	15K ohm 1/2w	102083
1	47K ohm 1/2w	101934
2	100K ohm 1/2w	101936
2	3.3 megohm 1/2w	102049
1	500 ohm pot	102025
2	25K ohm pot	102023
1	22K ohm 1/2w	101933

BAG 3

4	470pF 1Kv	100316
1	.001mF 1Kv	100328
1	.01mF 16v	100305
3	.033mF 16v	100344
5	.1mF 10v	100348
1	.15mF 100v	100345
1	1mF 16v	100306
1	4.7mF or 5mF 16v	100309
1	30mF 16v	100369
2	500mF 25v	100318

BAG 4

2	EN2907	102804
1	CS4410-4438	102808
2	IN914	100705
1	12v zener(IN4742)	100722

BAG 5

8	1 1/2" wire	103002
10	8" red wire	103041
2	20" shielded audio cable	103044

BAG 6

6	#4-40 nut	100932
3	#4-40 lockwasher	100941
3	#4-40x1 1/2" screw	100924
3	.15" spacer	101823
2	Mini jacks	101722
3	.7" spacer	101821

MISCELLANEOUS

1	PC board (modem)	100170
1	Assembly & Operator Manual	100515
1	Foil label set	101834

88-SIOB

BAG 1

1	MC7805	101074
5	74L00	101080
2	74L02	101072
2	74L04	101073
1	74L30	101082
3	74L193/93L66	101087
1	9601	101033
4	8T97	101040
1	COM2502	101065

BAG 2

1	12v zener	100722
2	2.2K ohm 1/2w	101945
1	7.5K ohm 1/2w	101992
1	47 ohm 1/2w	101922

BAG 3

2	30mF 10v elec	100369
10	.1mF 10v cer	100348
1	.001mF 10v cer	100359

BAG 4

1	Connector	101768
10	Terminals	101769
1	Pin (10)	101812
1	40 pin socket	102106
1	Heatsink (small)	101870

BAG 5

4	6-32x1/2" screw	100918
1	#6 nut	100933
1	#6 lockwasher	100942
1	6-32x1/4" screw	100917

BAG 6

13	6" wire	103017
6	1 1/2" wire	103002
1	Edge connector	101864
2	Card guides	101714

MISCELLANEOUS

1	PC board	100132
1	Manual	101559

*****88-ACR ERRATA SHEET*****

DUE TO CHANGES IN THE PC BOARD CONSTRUCTION, THE ASSEMBLY OF THE 88-ACR MODEM BOARD MUST BE ALTERED ACCORDING TO THE FOLLOWING INFORMATION.

PAGE 3: IC E, listed as a 74L93 will be substituted with a 7493.

PAGE 6: The instructions for installing the trim pots should be followed with the exception that they will now be installed on the back (non-silk-screened) side of the PC board.

PAGE 16: There are two ground connections mentioned for the MODEM board. The board itself has three pads labeled GND. The two pads to be used are the second and third pads from the end with the "GND" label.

PAGES 18 & 19: With the trim pots now mounted on the back side of the PC board, the mating of the two boards must be altered. The spacers now used to separate the boards will be .7 inch spacers. The screws themselves will be 1 1/2 inch screws.

Mount the boards themselves in the same manner shown in the drawing; except, the trim pots will be pointing towards the other board. When correctly oriented, the component sides of the two board will be on the outside edges, the back (non-silk-screened) sides of the boards will be towards each other.

ERRATA SHEET: The errata sheet contained in the manual should be followed with the following exceptions. The 500uf capacitor should be connected with the same orientation, and to the same points as shown in the drawing; but, it should be mounted on the back side of the board as with the trim pots.

Also, plastic spacers will now be added to all three of the screws instead of just one as indicated. Place all three onto the screws in the same manner as called for by the sheet instructions.

THE TEST PROGRAMS ARE TO BE CHANGED AS FOLLOWS:

OUTPUT TEST PROGRAM

Address Location:	Change Code To:
201	006
202	007
203	000
204	332
212	007

(cont. on back)

INPUT TEST PROGRAM

Address Location:

Change Code To:

001	006
002	017
003	000
004	332
010	007
340	006
341	017
342	000
343	332
347	007

PAGE 5: Resistor R50 should be changed from 220K-ohms to 22K-ohms,
red-red-orange.

88-ACR ERRATA SHEET

THE FOLLOWING ADDITIONS ARE TO BE MADE TO THE 88-ACR MODEM BOARD ASSEMBLY PROCEDURE ON THE PAGES INDICATED:

AFTER COMPLETING THE INSTRUCTIONS ON PAGES 10 & 11, INSTALL A 500uf ELECTROLYTIC CAPACITOR IN THE POSITION SHOWN IN THE DRAWING BELOW. BE CAREFUL NOT TO SHORT THE CAPACITOR LEADS TO ANY OTHER LANDS OR COMPONENTS. SOLDER THE NEGATIVE LEAD DIRECTLY TO THE PC LAND INDICATED IN THE DRAWING, AND INSERT THE POSITIVE LEAD INTO THE FEED-THROUGH HOLE INDICATED.

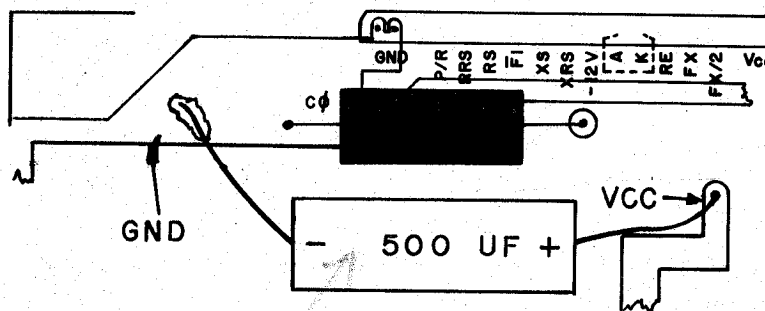

*MOUNT AS
ON BACK SIDE
OF BOARD*

PAGES 18 & 19: BEFORE INSERTING THE SCREW CLOSEST TO THE HEAT SINK ON THE S I/O B BOARD, PLACE A .15 INCH PLASTIC SPACER OVER IT. THIS IS TO INSULATE THE SCREW FROM THE PC LANDS ON THE S I/O B BOARD ITSELF.

8800 SERIAL I/O B BOARD ASSEMBLY

There are 19 integrated circuits (IC's) to be installed on the 8800 Serial I/O B Board. (88-SIOB) One of these, IC M, will be provided with a 40-pin IC socket. IC M itself should not be installed into the socket until the board is completely assembled.

- (✓) Referring to the component layout, set the 40-pin IC socket included in your kit into place and secure it with a piece of masking tape. (see drawing below)

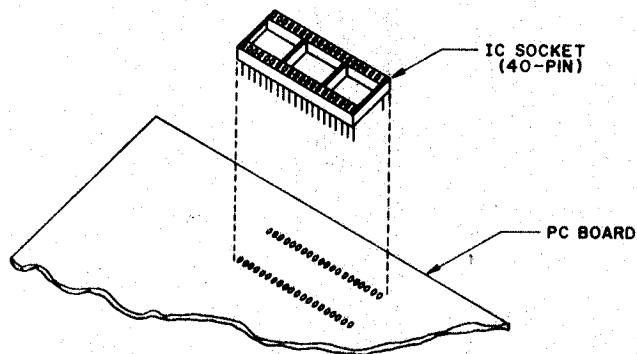

- (✓) Turn the board over and solder each pin to the foil pattern on the back side of the board. Be sure to solder each pin and be careful not to leave any solder bridges.
- (✓) Turn the board over again and remove the piece of masking tape.
- (✓) Referring to the component layout, remove the IC with the correct part number from its holder. If there are any bent pins, straighten these using needle-nose pliers. Ensure that you choose the IC with the correct part number as you install each one.

- (✓) Orient the IC so that its notched end is towards the arrowhead printed on the board, and pin 1 of the IC corresponds with the arrowhead itself.

NOTE: If the IC does not have a notch on one end, refer to the IC Orientation Chart included with your manual for the identification of pin 1.

- (✓) When you have the correct orientation, start the pins on one side of the IC into their respective holes on the silk-screened side of the PC board. DO NOT PUSH THE PINS IN ALL THE WAY. If you have difficulty getting the pins into the holes, use the tip of a small screwdriver to guide them.
- (✓) Start the pins on the other side of the IC into their holes in the same manner. When all of the pins have been started, set the IC in place by gently rocking it back and forth until it rests as close as possible to the board. Make sure that the IC is perfectly straight and as close as possible to the board; then tape it in place with a piece of masking tape.
- (✓) Turn the board over and solder each pin to the foil pattern on the back side of the board. Be sure to solder each pin and be careful not to leave any solder bridges.
- (✓) Turn the board over again and remove the piece of masking tape.

Use the same procedure to install each of the IC's. Be sure that you have the correct part number and the correct orientation as you install each one.

(✓) Install a 40-pin socket for IC M

(✓) IC's A, B, C, D, and G are 74L00's

(✓) IC's E and H are 74L04's

(✓) IC I is a 74L30

(✓) IC's J and S are 74L02's

(✓) IC's K, L, N and U are 8T97's

(✓) IC O is a 9601 (or 8T22A)

(✓) IC's P, Q and R are 74L193's

93466

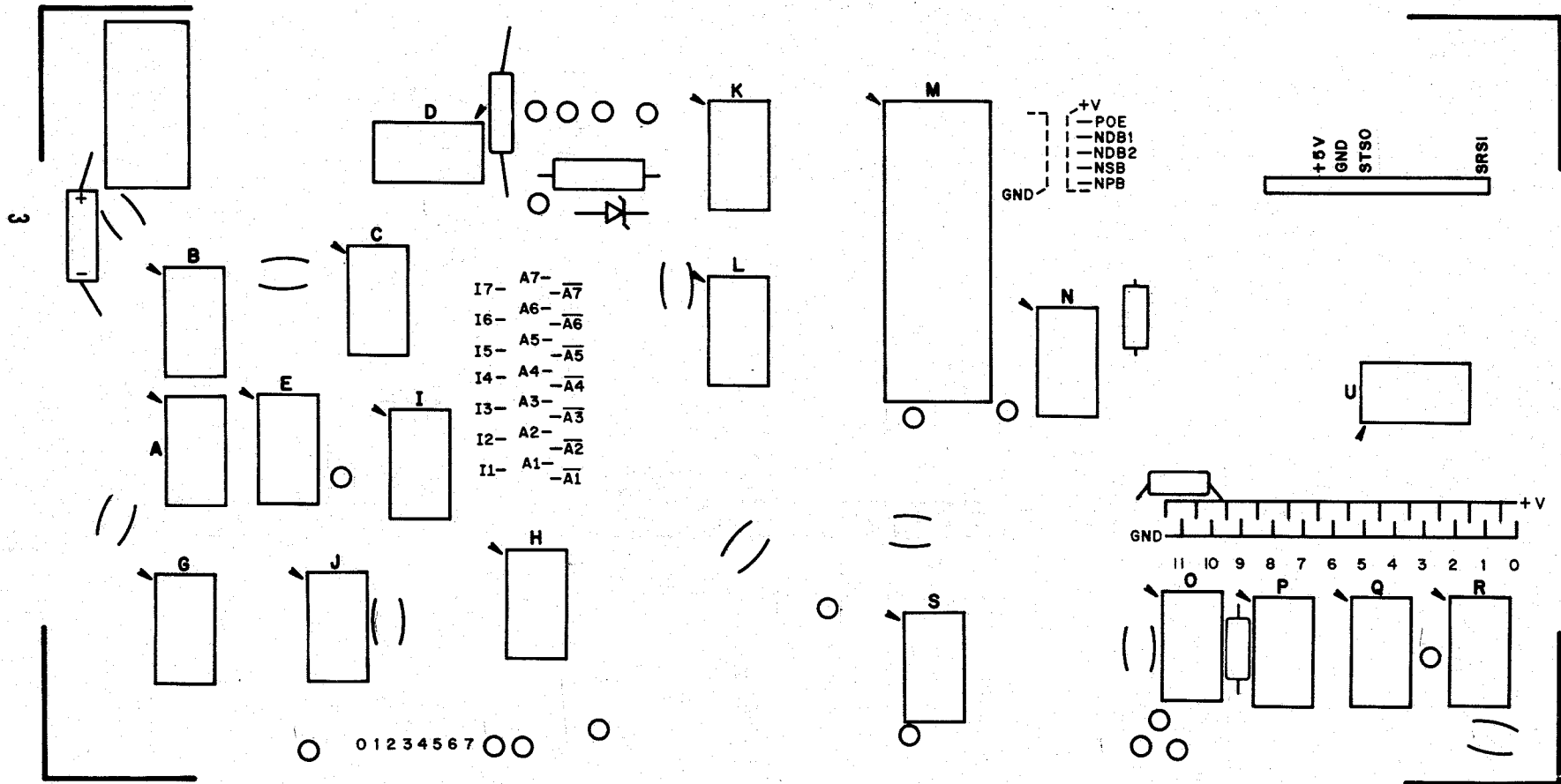

Resistor Installation

There are 4 resistors to be mounted on the 8800 Serial I/O B Board.

NOTE: Resistors are color-coded according to their value. The resistors in your kit will have four or possibly five bands of color. The fourth band in both cases will be gold or silver, indicating the tolerance. In the following instructions we will be concerned only with the three bands of color to one side of the gold or silver band. Be sure to match these three bands of color with those called for in the instructions as you install each resistor.

Using needle-nose pliers, bend the leads of the following resistors at right angles to match their respective holes on the PC board. (see component layout)

NOTE: All resistors on the 8800 Serial I/O B Board are either 1/4 or 1/2 Watt.

- (✓) Install resistor R1 (130-ohm, brown-orange-brown) into the correct holes on the silk-screened side of the PC board.
- (✓) Holding the resistor in place with one hand, turn the board over and bend the two leads slightly outward.
- (✓) Solder the leads to the foil pattern on the back side of the board; then clip off any excess lead lengths.

Referring to the component layout, install the remaining resistors in the same manner. Be sure you have the correct color-coding for each one as you install them.

NOTE: Save all of the component leads that you clip off for use later in the assembly procedure.

Capacitor Installation

There are 9 ceramic disk capacitors and 2 electrolytic capacitors to be installed on the 8800 Serial I/O B Board.

Refer to the component layout and install the ceramic disk capacitors according to the following procedure.

- () Choose the capacitor with the correct value as called for in the instructions. Straighten the two leads as necessary and bend them to fit their respective holes on the PC board.
- () Insert the capacitor into the correct holes from the silk-screened side of the board. Push the capacitor down until the ceramic insulation almost touches the foil pattern.
- () Holding the capacitor in place, turn the board over and bend the two leads slightly outward.
- () Solder the two leads to the foil pattern on the back side of the board; then clip off any excess lead lengths.

Install all of the ceramic disk capacitors in this manner. Be sure that you have the correct value capacitor as you install each one.

The two electrolytic capacitors for the Serial I/O Board have polarity requirements which must be noted before installation. Those contained in your kit may have one or possibly two of three types of polarity markings. To determine the correct orientation, look for the following: (see drawing above right)

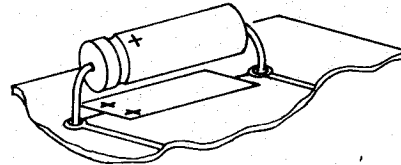

ELECTROLYTIC
CAPACITOR

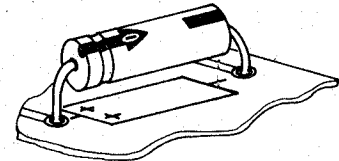

One type will have plus (+) signs on the positive end; another will have a band or a groove around the positive side in addition to the plus signs. The third type will have an arrow on it; in the tip of the arrow there is a negative (-) sign and the capacitor must be oriented so the arrow points to the negative polarity side.

Referring to the component layout, install the electrolytic capacitors on the board.

- () Bend the two leads of the capacitor with the correct value at right angles to match their respective holes on the board. Insert the capacitor into the holes on the silk-screened side of the board. Be sure to align the positive polarity side with the "+" signs printed on the board.
- () Holding the capacitor in place, turn the board over and bend the two leads slightly outward. Solder the leads to the foil pattern and clip off any excess lead lengths.
- () Install the second electrolytic capacitor in the same manner.

() C1 & C9 are 35uf

(/) C2 to C7, C10 & C11 are .1uf

(/) C8 is .001uf

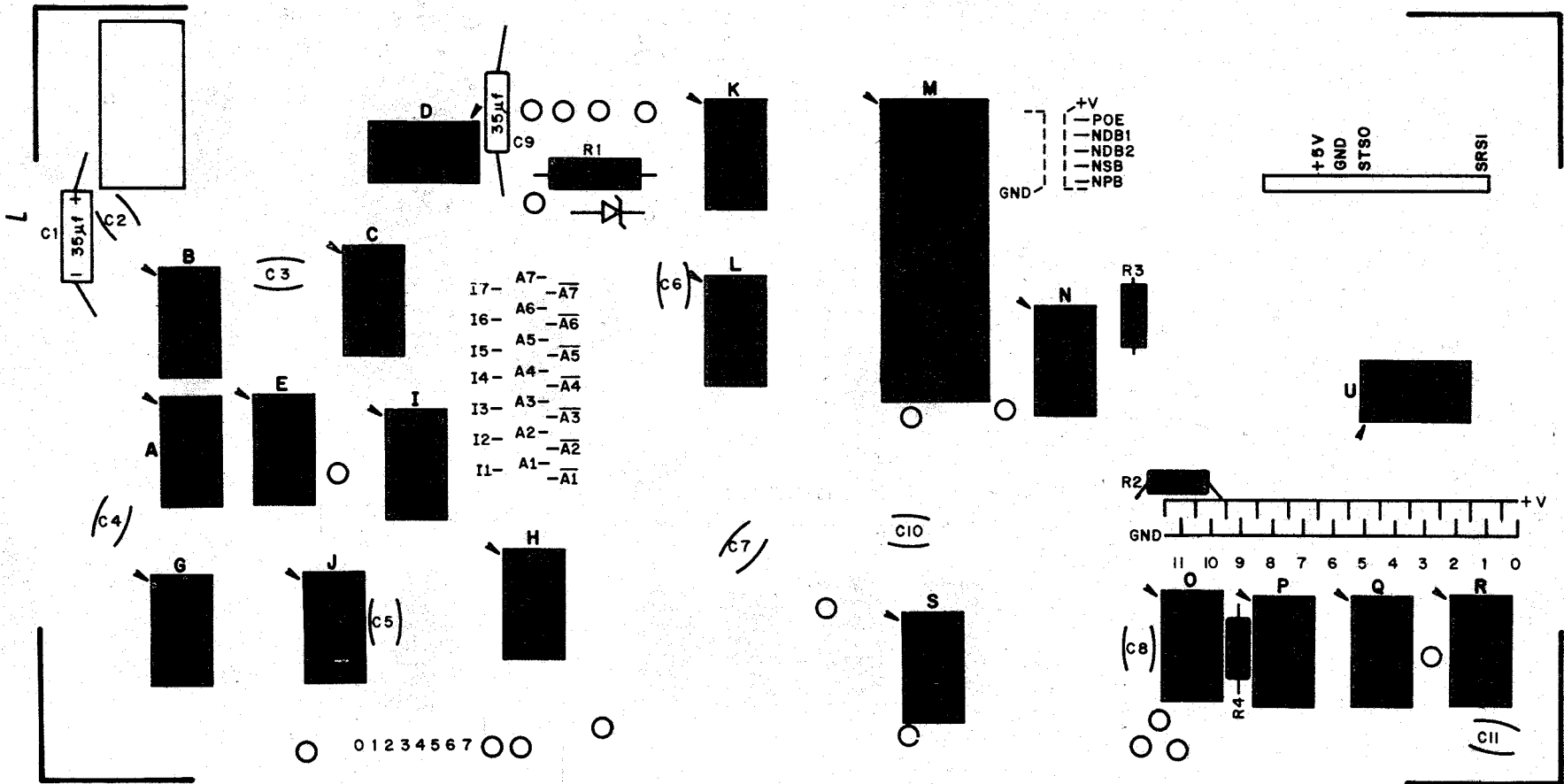

Diode Installation

There is one 12-volt zener diode to be installed on the 8800 Serial I/O B Board.

NOTE: Diodes are marked with a band on one end indicating the cathode end. The diode must be oriented so that the end with the band is towards the band printed on the board when being installed.

- (/) Referring to the component layout, bend the leads of zener diode Z1 at right angles to match the correct holes on the board.
- (/) Insert the diode into the correct holes from the silk-screened side of the board. Turn the board over and bend the two leads slightly outward.
- (/) Solder the two leads to the foil pattern on the back side of the board; then clip off any excess lead lengths.

() Z1 is a 12-volt zener diode

NOTE: The 12-volt zener will be marked "12V" or 1N4742.

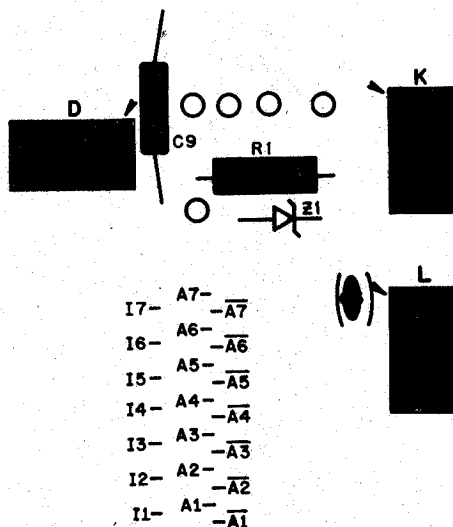

Voltage Regulator Installation

There is one MC7805 5-volt regulator to be installed on the 8800 Serial I/O B Board.

- (✓) Set the MC7805 in place on the board and align the mounting holes. (see drawing)
- (✓) Use a pencil to mark the point on each of the three leads where they line up with their respective holes on the board.
- (✓) Use needle-nose pliers to bend each of the three leads at a right angle on the points where you made the pencil marks.

✓ **NOTE:** Use heat-sink grease when installing this component. Apply the grease to all surfaces which come in contact with each other.

- (✓) Referring to the drawing, set the regulator and heat sink in place on the silk-screened side of the board. Use the smaller, 6 pronged, heat sink instead of the 8 pronged one shown in the drawing. Secure them as shown, holding the regulator in place as you tighten the nut.
- (✓) Turn the board over and solder the three leads to the foil pattern on the back side of the board. Be sure not to leave any solder bridges.
- (✓) Clip off any excess lead lengths.

() Install VR (MC7805)

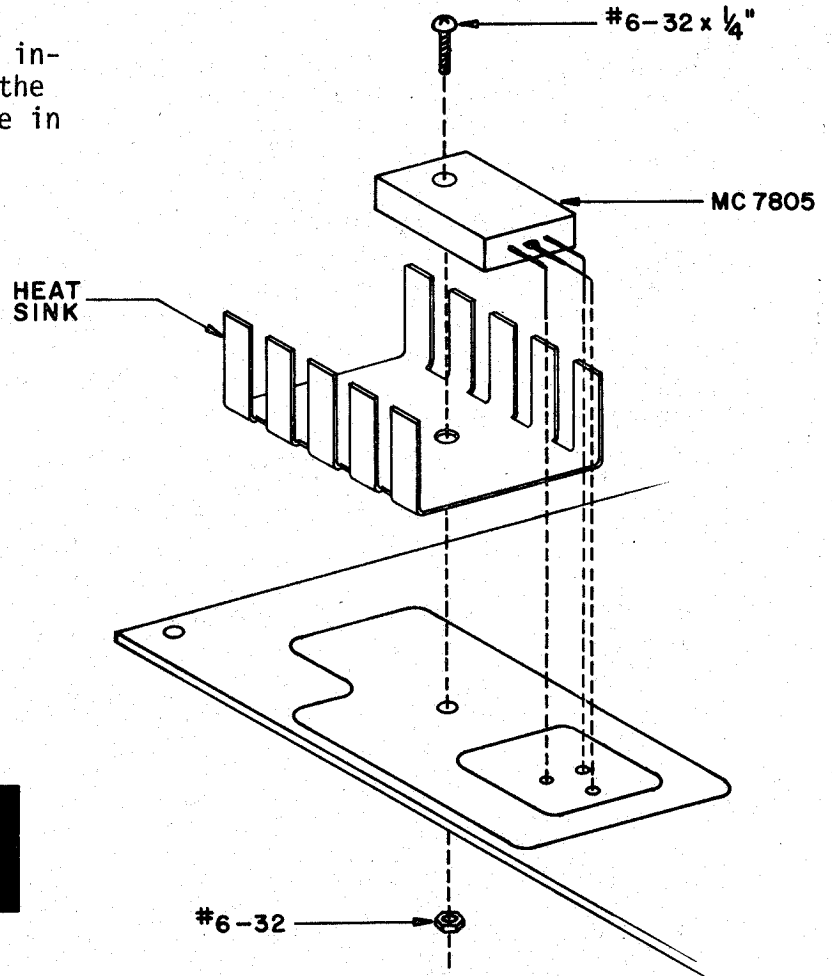
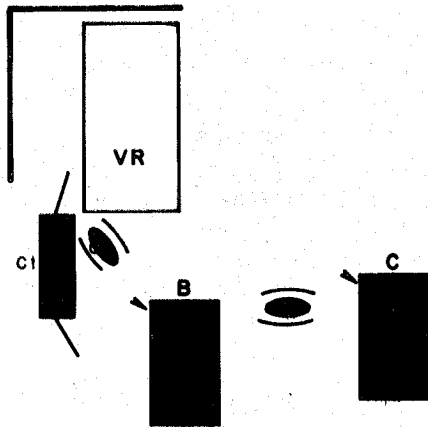

Hardwire Connections

There are 30 hardwire connections, with one optional connection, to be made on the 8800 Serial I/O B Board.

The first five connections to be made are near IC M, towards the top right corner of the board. Make these connections using 1 inch wires. Make each connection by inserting the wire from the silk-screened side of the board and soldering it on the back side. Be sure to clip off any excess lead lengths.

- (✓) Connect the pad labeled NSB according to the following information:

NSB--to--GND = 1 stop bit

NSB--to--+V = 2 stop bits

- (✓) Connect the pads labeled POE and NPB according to the following information:

NPB	POE	MODE
GND	GND	odd parity
GND	+V	even parity
+V	X	no parity

(X = don't care)

- (✓) Connect the pads labeled NDB1 and NDB2 according to the following information:

NDB1	NDB2	data bits/character
GND	GND	5
+V	GND	6
GND	+V	7
+V	+V	8

NOTE: The pad labeled "S0" between IC's Q & R will not be used except with the 88-ACR interface. (see ACR assembly)

There are 6 jumper connections to be made on this board. Make these using 6 inch wires in the same manner as the previous connections with 1 inch wires.

- (✓) Connect pad -V to pad -V

- (✓) Connect pad 0 to pad 0

- (✓) Connect pad I to pad I

- (✓) Connect pad PC to pad PC

- (✓) Connect pad C to pad C

- (✓) Connect pad H to pad H

The connections for the address selection and the BAUD rate selection are made with component leads saved from earlier steps in the assembly procedure. Bend the leads as necessary to fit their respective holes on the board and insert them from the silk-screened side. Solder them on the back side of the board and clip off any excess lead lengths.

Refer to the I/O ADDRESS SELECTION CHART and the I/O BAUD RATE SELECTION CHART for the necessary information for making these selections.

NOTE: In the address selection, wire pads I1 through I7 to A1 & A1 through A7 & A7 as indicated in the chart to obtain the octal address listed in the left column.

Refer to the Theory of Operation manual for further explanations of these two functions.

Vectored Interrupt

This is an optional function on the 8800 system, and need not be used at all. If it is to be used, it must be used in conjunction with the 88-VI vectored interrupt card. There is one exception to this which will be explained towards the end of this section.

The 8800 Serial I/O B Board has provisions for vectored interrupt hardware connections. This provides the user with the option of selecting a priority level for the input device and the output device, or a single priority level for both. The vectored interrupt offers 8 levels of priority, 0 through 7, with 7 being the highest priority level.

There are three pads at the top of the board labeled "OUT", "IN" and "BH". There are eight pads at the bottom of the board numbered 0 through 7. The eight numbered pads correspond to the eight priority levels respectively.

Use 6 inch wires to make these connections in the same manner as the previous jumper connections.

You may connect the "OUT" (output device) pad to some priority level, and the "IN" (input device) pad to some priority level; or you may connect the "BH" (both devices) pad to a desired priority level for both devices. If the "BH" pad is used to set the priority level, the "OUT" and "IN" pads should not be used.

- () Connect the vectored interrupt priority level as desired per the information above.

It is possible to obtain a single level of interrupt priority on this board without the necessity of the 88-VI vectored interrupt card.

This may be used only on one of the I/O cards in your system, and only one of the three pads ("OUT", "IN" and "BH") can be used to make the connection.

- () For a single level of priority interrupt, connect a jumper wire between the pad near the bottom of the board labeled "INT" and the desired pad at the top of the board. Remember only one of the three pads "OUT", "IN" or "BH" may be used and only one I/O board may be connected in this manner.

Make all hardwire connections as described in the instructions.

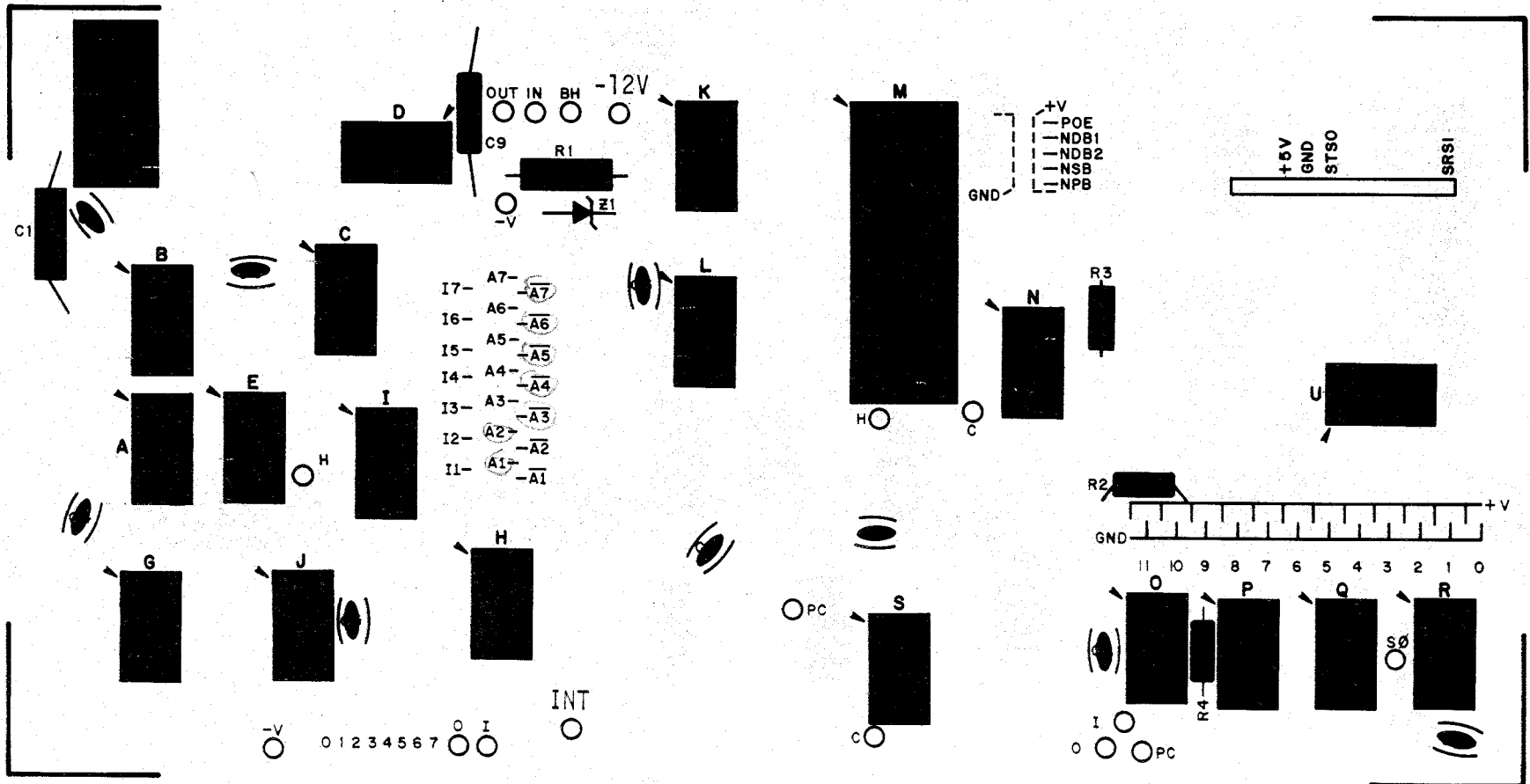

Wafer Connector Installation

There is one 10-pin male connector to be installed on the 8800 Serial I/O B Board.

() Referring to the drawing below, insert the 10-pin wafer connector into the correct holes on the board from the silk-screened side. Be sure to insert the side with the shorter, straight pins.

(/) Holding the connector in place, turn the board over and solder the 10 pins to the foil pattern on the back side of the board.

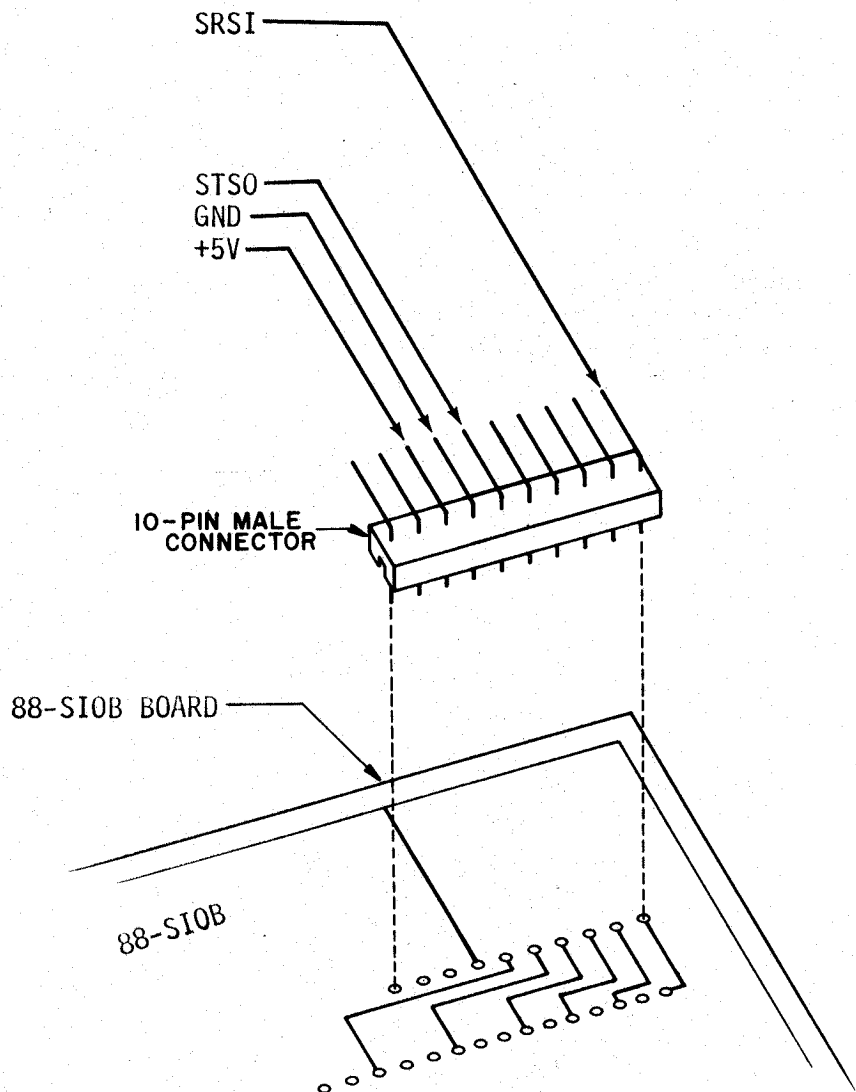

Board Installation

- () IC M may now be installed into its socket on the 8800 Serial I/O B board. Do this very carefully and remember this is a MOS integrated circuit and very sensitive to static electricity.
- () Refer to page 64 in the assembly manual "EXPANDER BOARD 8800 M/BD ASSEMBLY" and install the edge connector provided with the board according to the procedure described there.
- () Press the 8800 Serial I/O B Board into the edge connector just installed. The board should be oriented the same way as the other boards already installed; i.e. the silk-screened side should be facing the right side of the unit viewed from the front panel.

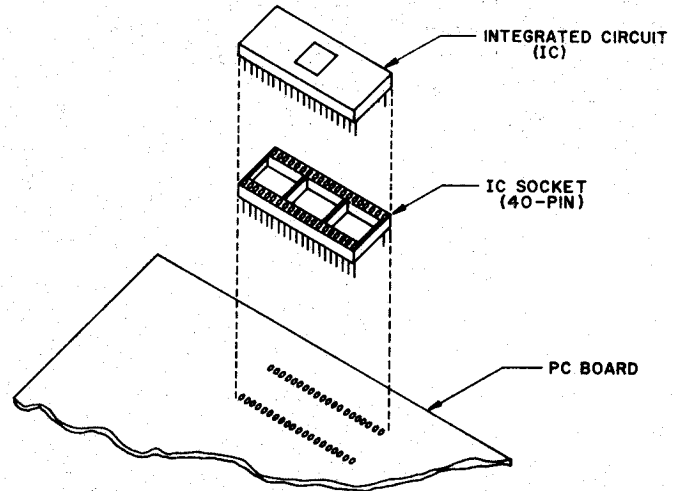

SEE
NOTE
PAGE II

I/O Connector Wiring

There is a 10-pin female connector provided with your kit, along with a multi-conductor cable. These must be wired together according to the following procedure.

- () Using a small sharp knife, strip $1\frac{1}{4}$ inches of cable sheath from one end and 2 inches of cable sheath from the other end of the cable. Do this by cutting a circle around the sheath, being very careful not to cut into the insulation of the wires inside, and pulling the end off of the wires.
- () On the end with $1\frac{1}{4}$ inches of wires exposed, strip $\frac{1}{8}$ inch of insulation from the ends of each of the wires and tin the exposed portion by applying a thin coat of solder.
- () Referring to the drawing below, install one of the connector pins onto the end of each of the necessary wires. Do this by crimping the wire into place; then soldering the end to the pin itself. The number of wires used will depend on whether pwr. & gnd. are required externally.
- () Referring to the drawing on the following page, insert the pins one at a time into the female connector. As you insert each pin, note the color of the wire and label the same wire on the opposite end with the designation indicated on the drawing. It is very important that you maintain the wire orientation indicated in the drawing.

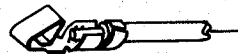

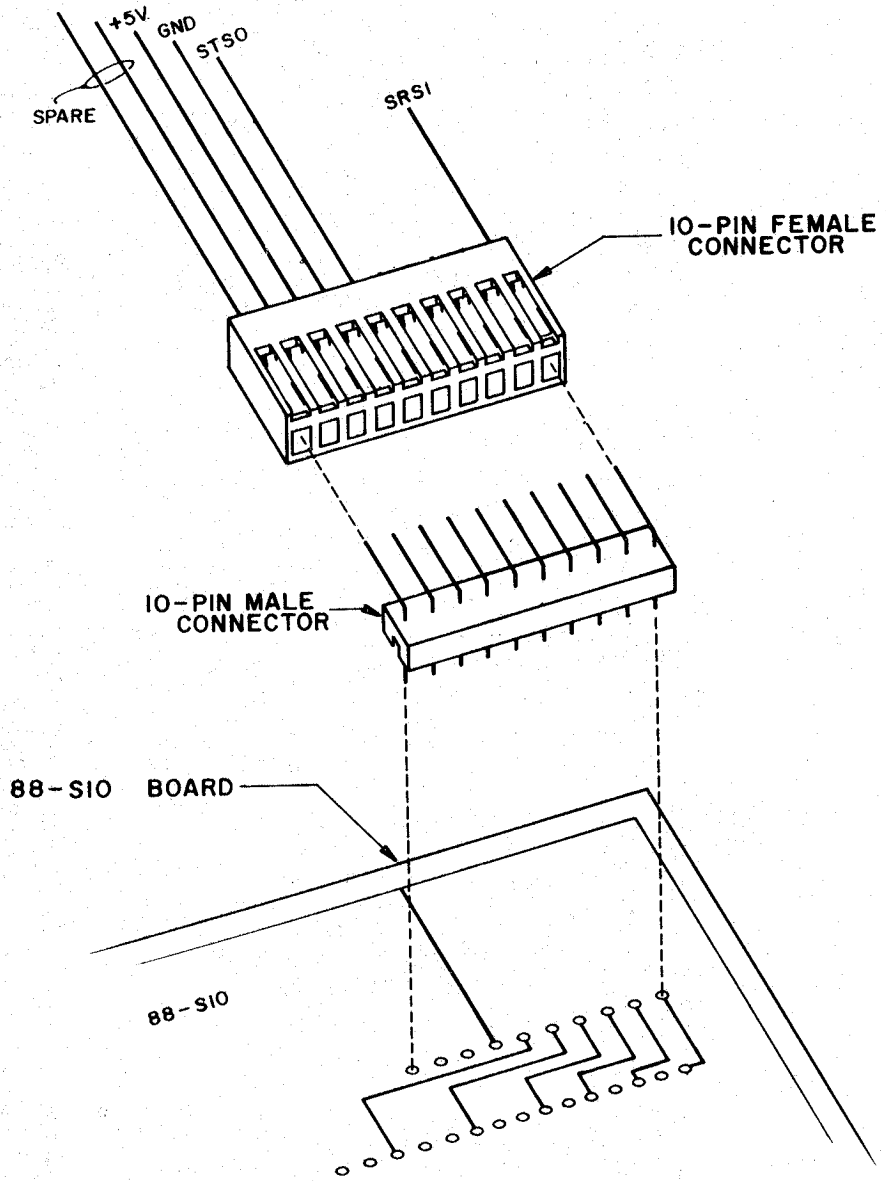
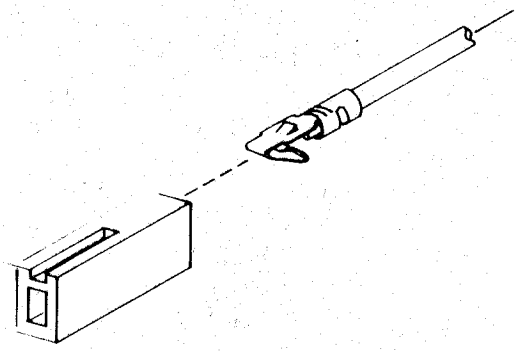

I/O Device Interconnections

The following signals are available on the 8800 Serial I/O B Board I/O Connector.

STSO----Serial Data Output

SRSI----Serial Data Input

GROUND

+5 VOLTS--(do not use unless external power is required,
and do not use greater than 100ma.)

There are also several spare pins which are not used.

The signals on this board have the following characteristics:

logic high level = +2v min., +5.5v max.--output current 40ma

logic low level = -1.5v min., +.8v max.--input current 500ua

There are several openings provided in the 8800 Back Panel for interfacing connections to exit the computer.

The connections to the device itself are to be made according to the device specifications.

There are spaces provided on the side of the back panel opposite the transformers for the mounting of 25-pin connectors. Both male and female connectors are included with your kit. These connectors are to be wired according to the device specifications also.

I/O ADDRESS SELECTION CHART

ADDRESS OCTAL	CONNECTIONS						
	I7	I6	I5	I4	I3	I2	I1
000	$\overline{A7}$	$\overline{A6}$	$\overline{A5}$	$\overline{A4}$	$\overline{A3}$	$\overline{A2}$	$\overline{A1}$
002	$\overline{A7}$	$\overline{A6}$	$\overline{A5}$	$\overline{A4}$	$\overline{A3}$	$\overline{A2}$	A1
004	$\overline{A7}$	$\overline{A6}$	$\overline{A5}$	$\overline{A4}$	$\overline{A3}$	A2	$\overline{A1}$
→ 006	$\overline{A7}$	$\overline{A6}$	$\overline{A5}$	$\overline{A4}$	$\overline{A3}$	A2	A1
010	$\overline{A7}$	$\overline{A6}$	$\overline{A5}$	$\overline{A4}$	A3	$\overline{A2}$	$\overline{A1}$
012	$\overline{A7}$	$\overline{A6}$	$\overline{A5}$	$\overline{A4}$	A3	$\overline{A2}$	A1
014	$\overline{A7}$	$\overline{A6}$	$\overline{A5}$	$\overline{A4}$	A3	A2	$\overline{A1}$
016	$\overline{A7}$	$\overline{A6}$	$\overline{A5}$	$\overline{A4}$	A3	A2	A1
020	$\overline{A7}$	$\overline{A6}$	$\overline{A5}$	A4	$\overline{A3}$	$\overline{A2}$	$\overline{A1}$
022	$\overline{A7}$	$\overline{A6}$	$\overline{A5}$	A4	$\overline{A3}$	$\overline{A2}$	A1
024	$\overline{A7}$	$\overline{A6}$	$\overline{A5}$	A4	$\overline{A3}$	A2	$\overline{A1}$
026	$\overline{A7}$	$\overline{A6}$	$\overline{A5}$	A4	$\overline{A3}$	A2	A1
030	$\overline{A7}$	$\overline{A6}$	$\overline{A5}$	A4	A3	$\overline{A2}$	$\overline{A1}$
032	$\overline{A7}$	$\overline{A6}$	$\overline{A5}$	A4	A3	$\overline{A2}$	A1
034	$\overline{A7}$	$\overline{A6}$	$\overline{A5}$	A4	A3	A2	$\overline{A1}$
036	$\overline{A7}$	$\overline{A6}$	$\overline{A5}$	A4	A3	A2	A1
040	$\overline{A7}$	$\overline{A6}$	A5	$\overline{A4}$	$\overline{A3}$	$\overline{A2}$	$\overline{A1}$
042	$\overline{A7}$	$\overline{A6}$	A5	$\overline{A4}$	$\overline{A3}$	$\overline{A2}$	A1
044	$\overline{A7}$	$\overline{A6}$	A5	$\overline{A4}$	$\overline{A3}$	A2	$\overline{A1}$
046	$\overline{A7}$	$\overline{A6}$	A5	$\overline{A4}$	$\overline{A3}$	A2	A1
050	$\overline{A7}$	$\overline{A6}$	A5	$\overline{A4}$	A3	$\overline{A2}$	$\overline{A1}$
052	$\overline{A7}$	$\overline{A6}$	A5	$\overline{A4}$	A3	$\overline{A2}$	A1
054	$\overline{A7}$	$\overline{A6}$	A5	$\overline{A4}$	A3	A2	$\overline{A1}$
056	$\overline{A7}$	$\overline{A6}$	A5	$\overline{A4}$	A3	A2	A1
060	$\overline{A7}$	$\overline{A6}$	A5	A4	$\overline{A3}$	$\overline{A2}$	$\overline{A1}$

ADDRESS OCTAL	CONNECTIONS						
	I7	I6	I5	I4	I3	I2	I1
062	$\overline{A7}$	$\overline{A6}$	A5	A4	$\overline{A3}$	$\overline{A2}$	A1
064	$\overline{A7}$	$\overline{A6}$	A5	A4	$\overline{A3}$	A2	$\overline{A1}$
066	$\overline{A7}$	$\overline{A6}$	A5	A4	$\overline{A3}$	A2	A1
070	$\overline{A7}$	$\overline{A6}$	A5	A4	A3	$\overline{A2}$	$\overline{A1}$
072	$\overline{A7}$	$\overline{A6}$	A5	A4	A3	$\overline{A2}$	A1
074	$\overline{A7}$	$\overline{A6}$	A5	A4	A3	A2	$\overline{A1}$
076	$\overline{A7}$	$\overline{A6}$	A5	A4	A3	A2	A1
100	$\overline{A7}$	A6	$\overline{A5}$	$\overline{A4}$	$\overline{A3}$	$\overline{A2}$	$\overline{A1}$
102	$\overline{A7}$	A6	$\overline{A5}$	$\overline{A4}$	$\overline{A3}$	$\overline{A2}$	A1
104	$\overline{A7}$	A6	$\overline{A5}$	$\overline{A4}$	$\overline{A3}$	A2	$\overline{A1}$
106	$\overline{A7}$	A6	$\overline{A5}$	$\overline{A4}$	$\overline{A3}$	A2	A1
110	$\overline{A7}$	A6	$\overline{A5}$	$\overline{A4}$	A3	$\overline{A2}$	$\overline{A1}$
112	$\overline{A7}$	A6	$\overline{A5}$	$\overline{A4}$	A3	$\overline{A2}$	A1
114	$\overline{A7}$	A6	$\overline{A5}$	$\overline{A4}$	A3	A2	$\overline{A1}$
116	$\overline{A7}$	A6	$\overline{A5}$	$\overline{A4}$	A3	A2	A1
120	$\overline{A7}$	A6	$\overline{A5}$	A4	$\overline{A3}$	$\overline{A2}$	$\overline{A1}$
122	$\overline{A7}$	A6	$\overline{A5}$	A4	$\overline{A3}$	$\overline{A2}$	A1
124	$\overline{A7}$	A6	$\overline{A5}$	A4	$\overline{A3}$	A2	$\overline{A1}$
126	$\overline{A7}$	A6	$\overline{A5}$	A4	$\overline{A3}$	A2	A1
130	$\overline{A7}$	A6	$\overline{A5}$	A4	A3	$\overline{A2}$	$\overline{A1}$
132	$\overline{A7}$	A6	$\overline{A5}$	A4	A3	$\overline{A2}$	A1
134	$\overline{A7}$	A6	$\overline{A5}$	A4	A3	A2	$\overline{A1}$
136	$\overline{A7}$	A6	$\overline{A5}$	A4	A3	A2	A1
140	$\overline{A7}$	A6	A5	$\overline{A4}$	$\overline{A3}$	$\overline{A2}$	$\overline{A1}$
142	$\overline{A7}$	A6	A5	$\overline{A4}$	$\overline{A3}$	$\overline{A2}$	A1

ADDRESS OCTAL	CONNECTIONS						
	I7	I6	I5	I4	I3	I2	I1
144	$\overline{A7}$	A6	A5	$\overline{A4}$	$\overline{A3}$	A2	$\overline{A1}$
146	$\overline{A7}$	A6	A5	$\overline{A4}$	$\overline{A3}$	A2	A1
150	$\overline{A7}$	A6	A5	$\overline{A4}$	A3	$\overline{A2}$	$\overline{A1}$
152	$\overline{A7}$	A6	A5	$\overline{A4}$	A3	$\overline{A2}$	A1
154	$\overline{A7}$	A6	A5	$\overline{A4}$	A3	A2	$\overline{A1}$
156	$\overline{A7}$	A6	A5	$\overline{A4}$	A3	A2	A1
160	$\overline{A7}$	A6	A5	A4	$\overline{A3}$	$\overline{A2}$	$\overline{A1}$
162	$\overline{A7}$	A6	A5	A4	$\overline{A3}$	$\overline{A2}$	A1
164	$\overline{A7}$	A6	A5	A4	$\overline{A3}$	A2	$\overline{A1}$
166	$\overline{A7}$	A6	A5	A4	$\overline{A3}$	A2	A1
170	$\overline{A7}$	A6	A5	A4	A3	$\overline{A2}$	$\overline{A1}$
172	$\overline{A7}$	A6	A5	A4	A3	$\overline{A2}$	A1
174	$\overline{A7}$	A6	A5	A4	A3	A2	$\overline{A1}$
176	$\overline{A7}$	A6	A5	A4	A3	A2	A1
200	A7	$\overline{A6}$	$\overline{A5}$	$\overline{A4}$	$\overline{A3}$	$\overline{A2}$	$\overline{A1}$
202	A7	$\overline{A6}$	$\overline{A5}$	$\overline{A4}$	$\overline{A3}$	$\overline{A2}$	A1
204	A7	$\overline{A6}$	$\overline{A5}$	$\overline{A4}$	$\overline{A3}$	A2	$\overline{A1}$
206	A7	$\overline{A6}$	$\overline{A5}$	$\overline{A4}$	$\overline{A3}$	A2	A1
210	A7	$\overline{A6}$	$\overline{A5}$	$\overline{A4}$	A3	$\overline{A2}$	$\overline{A1}$
212	A7	$\overline{A6}$	$\overline{A5}$	$\overline{A4}$	A3	$\overline{A2}$	A1
214	A7	$\overline{A6}$	$\overline{A5}$	$\overline{A4}$	A3	A2	$\overline{A1}$
216	A7	$\overline{A6}$	$\overline{A5}$	$\overline{A4}$	A3	A2	A1
220	A7	$\overline{A6}$	$\overline{A5}$	A4	$\overline{A3}$	$\overline{A2}$	$\overline{A1}$
222	A7	$\overline{A6}$	$\overline{A5}$	A4	$\overline{A3}$	$\overline{A2}$	A1
224	A7	$\overline{A6}$	$\overline{A5}$	A4	$\overline{A3}$	A2	$\overline{A1}$

ADDRESS OCTAL	CONNECTIONS						
	I7	I6	I5	I4	I3	I2	I1
226	A7	$\overline{A6}$	$\overline{A5}$	A4	$\overline{A3}$	A2	A1
230	A7	$\overline{A6}$	$\overline{A5}$	A4	A3	$\overline{A2}$	$\overline{A1}$
232	A7	$\overline{A6}$	$\overline{A5}$	A4	A3	$\overline{A2}$	A1
234	A7	$\overline{A6}$	$\overline{A5}$	A4	A3	A2	$\overline{A1}$
236	A7	$\overline{A6}$	$\overline{A5}$	A4	A3	A2	A1
240	A7	$\overline{A6}$	A5	$\overline{A4}$	$\overline{A3}$	$\overline{A2}$	$\overline{A1}$
242	A7	$\overline{A6}$	A5	$\overline{A4}$	$\overline{A3}$	$\overline{A2}$	A1
244	A7	$\overline{A6}$	A5	$\overline{A4}$	$\overline{A3}$	A2	$\overline{A1}$
246	A7	$\overline{A6}$	A5	$\overline{A4}$	$\overline{A3}$	A2	A1
250	A7	$\overline{A6}$	A5	$\overline{A4}$	A3	$\overline{A2}$	$\overline{A1}$
252	A7	$\overline{A6}$	A5	$\overline{A4}$	A3	$\overline{A2}$	A1
254	A7	$\overline{A6}$	A5	$\overline{A4}$	A3	A2	$\overline{A1}$
256	A7	$\overline{A6}$	A5	$\overline{A4}$	A3	A2	A1
260	A7	$\overline{A6}$	A5	A4	$\overline{A3}$	$\overline{A2}$	$\overline{A1}$
262	A7	$\overline{A6}$	A5	A4	$\overline{A3}$	$\overline{A2}$	A1
264	A7	$\overline{A6}$	A5	A4	$\overline{A3}$	A2	$\overline{A1}$
266	A7	$\overline{A6}$	A5	A4	$\overline{A3}$	A2	A1
270	A7	$\overline{A6}$	A5	A4	A3	$\overline{A2}$	$\overline{A1}$
272	A7	$\overline{A6}$	A5	A4	A3	$\overline{A2}$	A1
274	A7	$\overline{A6}$	A5	A4	A3	A2	$\overline{A1}$
276	A7	$\overline{A6}$	A5	A4	A3	A2	A1
300	A7	A6	$\overline{A5}$	$\overline{A4}$	$\overline{A3}$	$\overline{A2}$	$\overline{A1}$
302	A7	A6	$\overline{A5}$	$\overline{A4}$	$\overline{A3}$	$\overline{A2}$	A1
304	A7	A6	$\overline{A5}$	$\overline{A4}$	$\overline{A3}$	A2	$\overline{A1}$
306	A7	A6	$\overline{A5}$	$\overline{A4}$	$\overline{A3}$	A2	A1

ADDRESS OCTAL	CONNECTIONS						
	I7	I6	I5	I4	I3	I2	I1
310	A7	A6	$\overline{A5}$	$\overline{A4}$	$\overline{A3}$	A2	$\overline{A1}$
312	A7	A6	$\overline{A5}$	$\overline{A4}$	A3	$\overline{A2}$	A1
314	A7	A6	$\overline{A5}$	$\overline{A4}$	A3	A2	$\overline{A1}$
316	A7	A6	$\overline{A5}$	$\overline{A4}$	A3	A2	A1
320	A7	A6	$\overline{A5}$	A4	$\overline{A3}$	$\overline{A2}$	$\overline{A1}$
322	A7	A6	$\overline{A5}$	A4	$\overline{A3}$	$\overline{A2}$	A1
324	A7	A6	$\overline{A5}$	A4	$\overline{A3}$	A2	$\overline{A1}$
326	A7	A6	$\overline{A5}$	A4	$\overline{A3}$	A2	A1
330	A7	A6	$\overline{A5}$	A4	A3	$\overline{A2}$	$\overline{A1}$
332	A7	A6	$\overline{A5}$	A4	A3	$\overline{A2}$	A1
334	A7	A6	$\overline{A5}$	A4	A3	A2	$\overline{A1}$
336	A7	A6	$\overline{A5}$	A4	A3	A2	A1
340	A7	A6	A5	$\overline{A4}$	$\overline{A3}$	$\overline{A2}$	$\overline{A1}$
342	A7	A6	A5	$\overline{A4}$	$\overline{A3}$	$\overline{A2}$	A1
344	A7	A6	A5	$\overline{A4}$	$\overline{A3}$	A2	$\overline{A1}$
346	A7	A6	A5	$\overline{A4}$	$\overline{A3}$	A2	A1
350	A7	A6	A5	$\overline{A4}$	A3	$\overline{A2}$	$\overline{A1}$
352	A7	A6	A5	$\overline{A4}$	A3	$\overline{A2}$	A1
354	A7	A6	A5	$\overline{A4}$	A3	A2	$\overline{A1}$
356	A7	A6	A5	$\overline{A4}$	A3	A2	A1
360	A7	A6	A5	A4	$\overline{A3}$	$\overline{A2}$	$\overline{A1}$
362	A7	A6	A5	A4	$\overline{A3}$	$\overline{A2}$	A1
364	A7	A6	A5	A4	$\overline{A3}$	A2	$\overline{A1}$
366	A7	A6	A5	A4	$\overline{A3}$	A2	A1
370	A7	A6	A5	A4	A3	$\overline{A2}$	$\overline{A1}$

ADDRESS OCTAL	CONNECTIONS						
	I7	I6	I5	I4	I3	I2	I1
372	A7	A6	A5	A4	A3	$\overline{A2}$	A1
374	A7	A6	A5	A4	A3	A2	$\overline{A1}$
376	A7	A6	A5	A4	A3	A2	A1

$$X \times .94 = \frac{9600}{.94}$$

I/O BAUD RATE SELECTION CHART

In the chart below, PRESET COUNT pads 0 through 11 correspond to pads 0 through 11 on the right side of the I/O board. The BAUD rate listed on the left can be obtained by wiring pads 0 through 11 according to the information in the chart; with "+V" for a 1 and "GND" for a 0.

$$\text{PRESET COUNT FREQ} = 4100 - \left(\frac{\text{PERIOD OF OUTPUT (}\mu\text{S)}}{.5 \mu\text{S}} \right)$$

FREQ. = BAUD RATE X 17.3611
SEE P.4 OF THEORY OF OPERATION

BAUD RATE	²⁰⁴⁸ 11	¹⁰²⁴ 10	512	256	¹²⁸ 7	64	³² 5	16	8	4	2	1	0	.5	.25	.125
	PRESET COUNT													X	X	X
110	1	0	1	1	1	0	0	1	0	1	0	0	0			
150	1	1	0	0	1	1	0	0	0	0	1	1				
✓ → 300	1	1	1	0	0	1	1	0	0	0	1	1				
600	1	1	1	1	0	0	1	1	0	1	0	0				
1200	1	1	1	1	1	0	0	1	1	1	0	0				
2400	1	1	1	1	1	1	0	1	0	0	0	0				
4800	1	1	1	1	1	1	1	0	1	0	1	0				
9600	1	1	1	1	1	1	1	1	0	0	0	0				
24000 19200	1	1	1	1	1	1	1	1	1	0	0	0				
25000	1	1	1	1	1	1	1	1	1	0	1	0				

READ THESE USING ABOVE FORMULA

4094

400KHZ
466.5



MODEM BOARD



ASSEMBLY



PROCEDURE



Integrated Circuit Installation

There are 8 integrated circuits (IC's) to be installed on the 88-ACR Modem Board.

Install each of the IC's according to the following procedure:

- (✓) Referring to the component layout, remove the IC with the correct part number from its holder. If there are any bent pins, straighten these using needle-nose pliers. Ensure that you choose the IC with the correct part number.
- (✓) Orient the IC so that its notched end corresponds with the notch printed on the board, and pin 1 of the IC corresponds with the arrowhead printed on the board.

NOTE: If the IC does not have a notch on one end, refer to the IC Orientation Chart included in your manual for the identification of pin 1.

- (✓) When you have the correct orientation, start the pins on one side of the IC into their respective holes on the silk-screened side of the PC board. **DO NOT PUSH THE PINS IN ALL THE WAY.** If you have difficulty getting the pins into the holes, use the tip of a small screwdriver to guide them.

- (✓) Start the pins on the other side of the IC into their respective holes in the same manner. When all of the pins have been started, set the IC into place by gently rocking it back and forth until it rests as close as possible to the board. Make sure that the IC is perfectly straight and as close to the board as possible; then tape it in place with a piece of masking tape.
- (✓) Turn the board over and solder each pin of the IC to the foil pattern on the back side of the board. Be sure to solder each pin, and be careful not to leave any solder bridges.
- (✓) Turn the board over again and remove the piece of masking tape.

Use the same procedure to install each of the IC's. Be sure that you have the correct part number and the correct orientation as you install each one.

- (/) IC A is a 741
- (/) IC B is a 741
- (/) IC C is an XR 210
- (/) IC E is a 74L93 *7493*
- () IC G is a 74L02
- (/) IC H is a 74L20
- (/) IC J is a 93L16
- (/) IC K is a 93L16

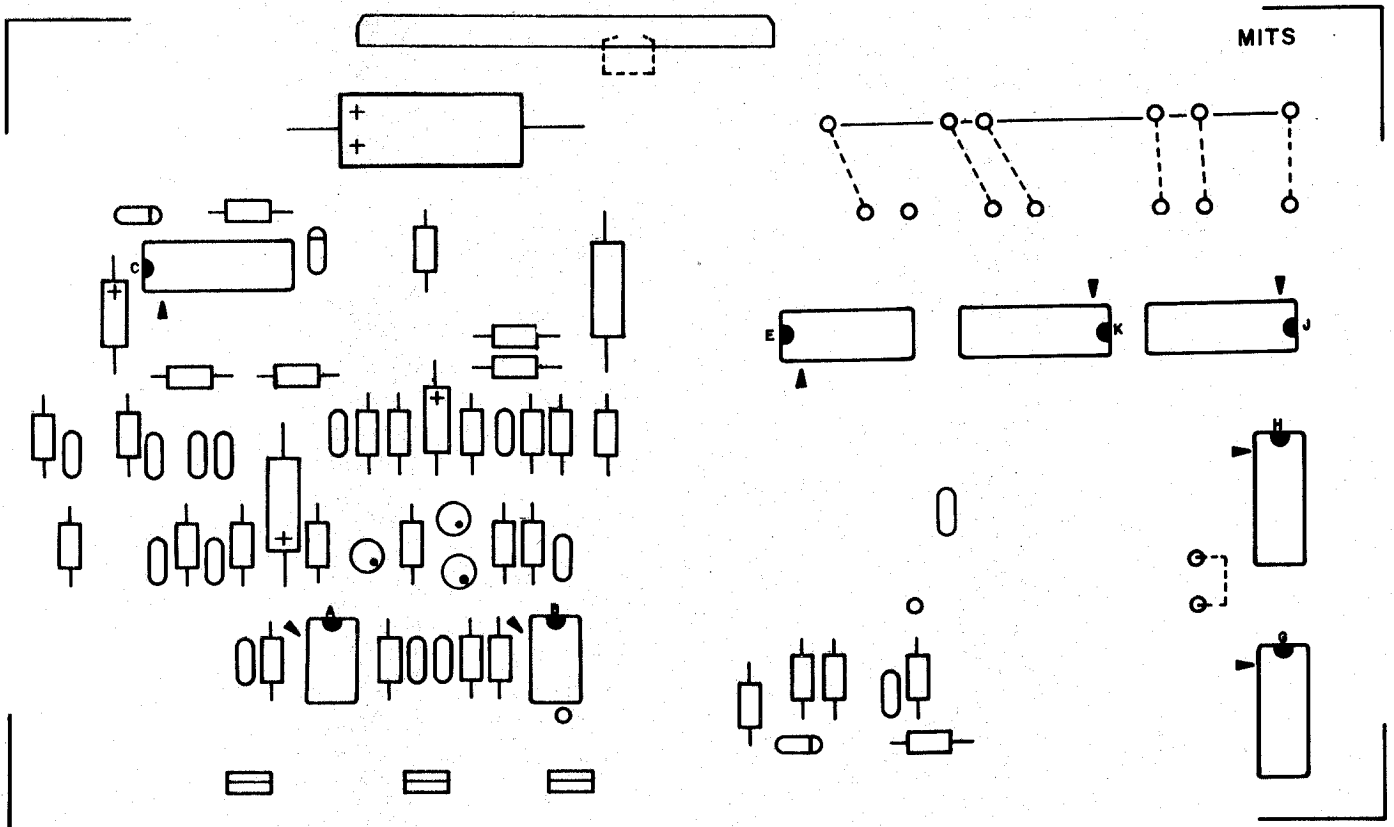

Resistor Installation

There are 30 resistors to be installed on the 88-ACR Modem Board.

NOTE: Resistors are color-coded according to their value. The resistors in your kit will have four or possibly five bands of color. The fourth band in both cases will be gold or silver, indicating the tolerance. In the following instructions we will be concerned only with the three bands of color to one side of the gold or silver band. Be sure to match these three bands of color with those called for in the instructions as you install each resistor.

Using needle-nose pliers, bend the leads of the resistors at right angles to match their respective holes on the PC board. (see component layout)

NOTE: All resistors on the 88-ACR Modem Board may be either 1/4 or 1/2 Watt.

- (1) Insert resistor R1 (4.7K-ohm, yellow-violet-red) into the correct holes from the silk-screened side of the PC board. (see component layout)
- (2) Holding the resistor in place with one hand, turn the board over and bend the two leads slightly outward.
- (3) Solder the leads to the foil pattern on the back side of the board; then clip off any excess lead lengths.

Referring to the component layout, install the remaining resistors in the same manner. Be sure you have the correct color-coding for each one as you install them.

- (/) R6, R8, R11, R16, R27 & R34 are 10K-ohm, brown-black-orange
- (/) R7 & R18 are 100K-ohm, brown-black-yellow
- (/) R10 & R15 are 3.3Meg-ohm, orange-orange-green
- (/) R12 & R51 are 1.5K-ohm, brown-green-red
- (/) R14 is 15K-ohm, brown-green-orange
- (/) R17 is 47K-ohm, yellow-violet-orange
- (/) R19, R21, R23, R25 & R33 are 4.7K-ohm, yellow-violet-red
- (/) R20 & R24 are 2.2K-ohm, red-red-red
- (/) R22 & R32 are 1K-ohm, brown-black-red
- (/) R26 is 3.3K-ohm, orange-orange-red
- (/) R28 is 8.2K-ohm, grey-red-red
- (/) R30 is 100-ohm, brown-black-brown
- (/) R36 & R49 are 470-ohm, yellow-violet-brown
- (/) R50 is ^{22K}220K-ohm, ~~red-red-yellow~~

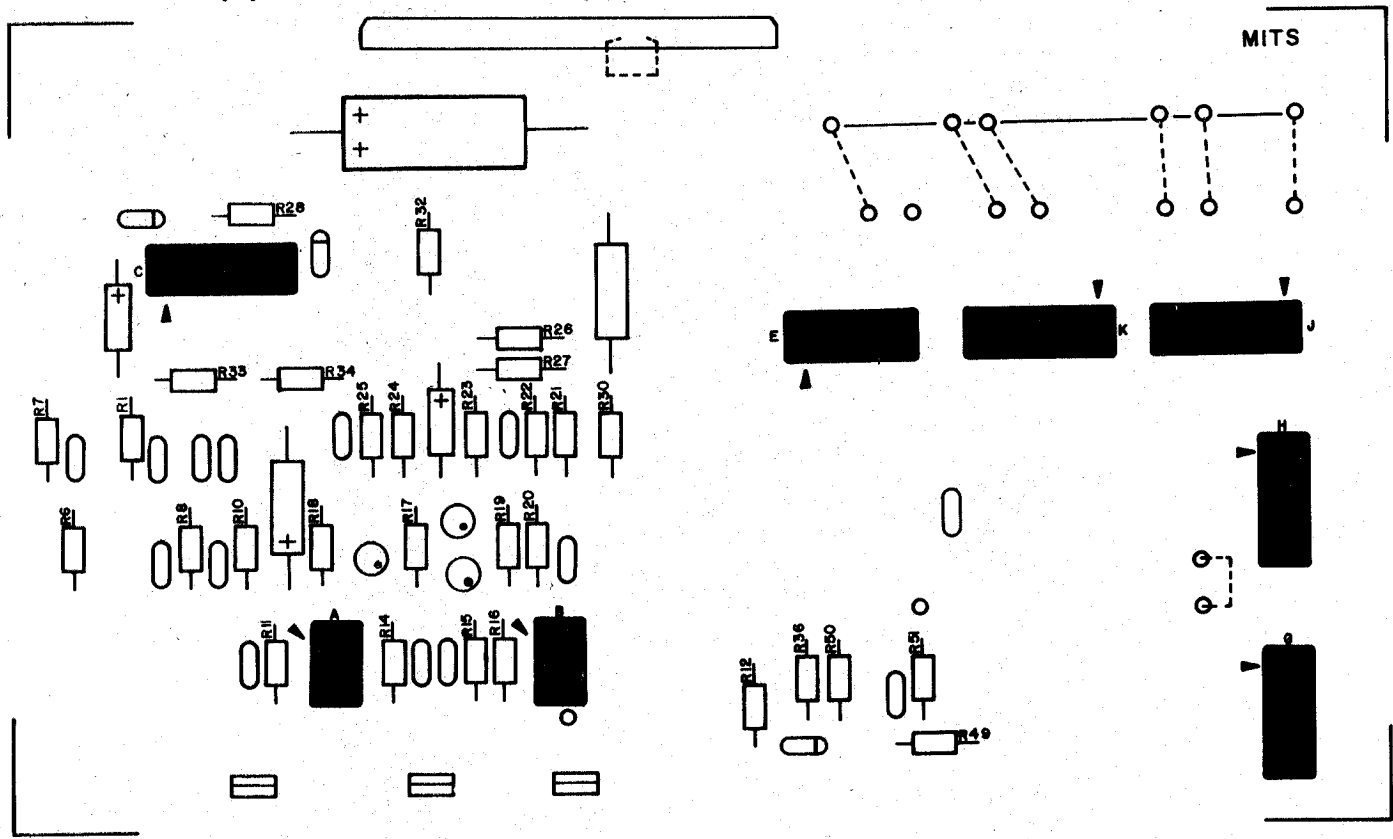

Trim Pot Installation

There are 3 trim pots (variable resistors) to be installed on the 88-ACR Modem Board.

There are two different value pots used on the board; R9 & R13 are 25K-ohms and R29 is 500-ohms. The identification markings on the three pots will be as follows:

R9 & R13 will be marked either "25K" or MTC253L1,
R29 will be marked either "500" or MTC52L1.

- (✓) Insert trim pot R9, 25K-ohms (MTC 253L1), into the correct holes from the ~~silk-screened~~ side of the PC board. The pot should mount vertically in the board into the three holes provided with the correct triangular spacing.
- (✓) Turn the board over and solder the three leads to the foil pattern on the back side of the board.

Install trim pots R13 & R29 in the same manner. Be sure you have the correct value pot in the correct location, and check to see that there are no solder bridges.

(/) R9 is 25K-ohms, MTC 253L1

() R13 is 25K-ohms, MTC 253L1

(/) R29 is 500-ohms, MTC 52L1

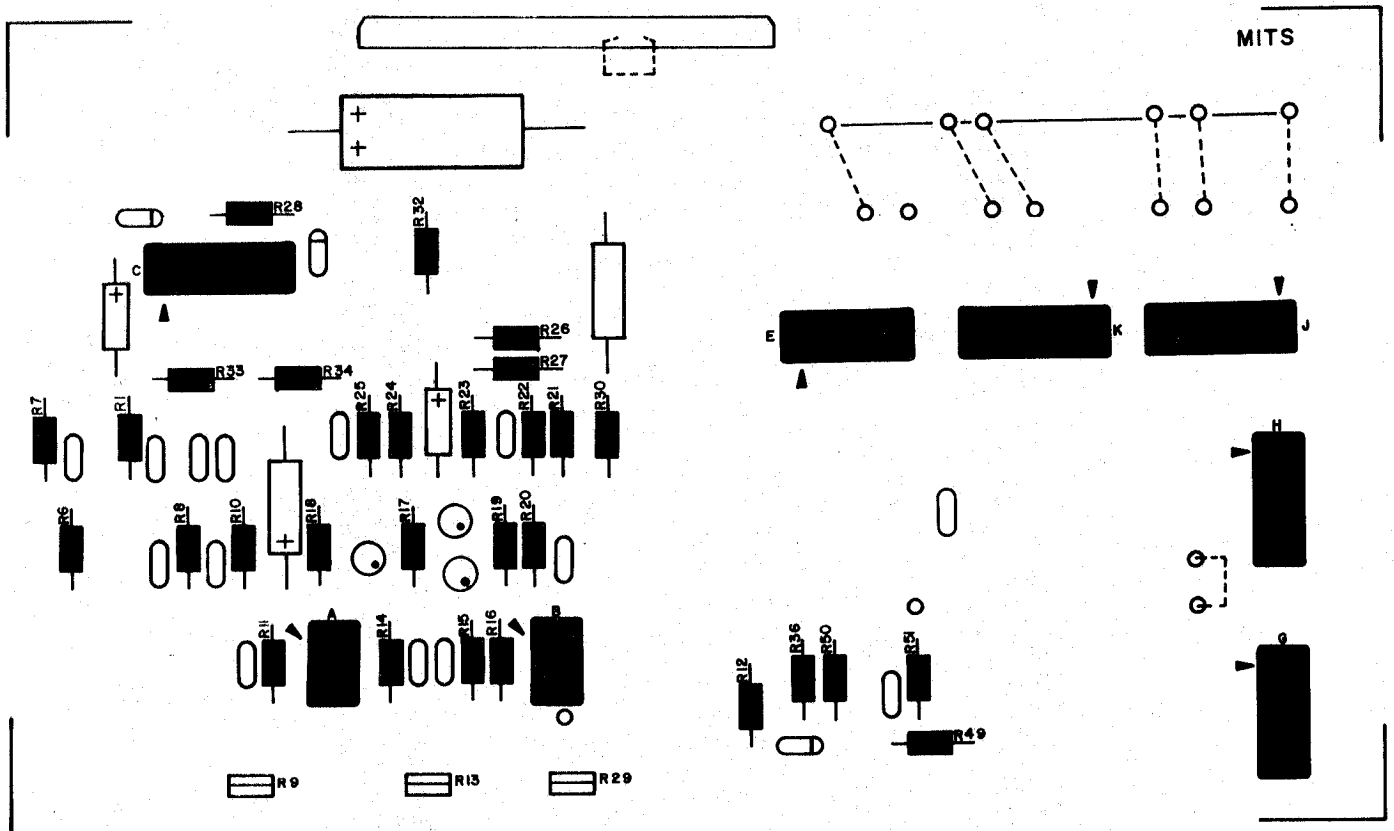

Capacitor Installation

There are 19 capacitors to be installed on the 88-ACR Modem board. Four of these are electrolytic, one is mylar, and the others are ceramic disk capacitors.

Refer to the component layout and install the mylar and ceramic disk capacitors according to the following procedure.

- () Choose the capacitor with the correct value as called for in the instructions. Straighten the two leads as necessary and bend them to fit their respective holes on the PC board.
- () Insert the capacitor into the correct holes from the silk-screened side of the board. Push the capacitor down until the insulation on the leads almost touches the foil pattern.
- () Holding the capacitor in place, turn the board over and bend the two leads slightly outward.
- () Solder the two leads to the foil pattern on the back side of the board; then clip off any excess lead lengths.

Install all of the ceramic disks and the mylar in this manner. Be sure that you have the correct value capacitor as you install each one.

The three electrolytic capacitors for the Modem board have polarity requirements which must be noted before installation. Those contained in your kit may have one or possibly two of three types of polarity markings. To determine the correct orientation, look for the following: (see drawing above right)

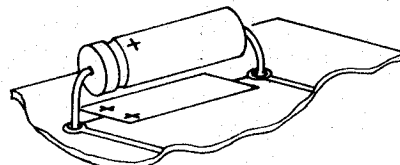

ELECTROLYTIC
CAPACITOR

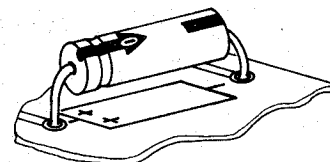

One type will have plus (+) signs on the positive end; another will have a band or a groove around the positive side in addition to the plus signs. The third type will have an arrow on it; in the tip of the arrow there is a negative (-) sign and the capacitor must be oriented so the arrow points to the negative polarity side.

Referring to the component layout, install the electrolytic capacitors onto the board according to the following procedure.

- () Bend the two leads of the capacitor with the correct value at right angles to match their respective holes on the board. Insert the capacitor into the holes from the silk-screened side of the board. Be sure to align the positive polarity side with the "+" signs printed on the board.
- () Holding the capacitor in place, turn the board over and bend the two leads slightly outward. Solder the leads to the foil pattern and clip off any excess lead lengths.

Install all 4 electrolytic capacitors in this manner.

- (/) C2 is .01uf
- (/) C3 is .001uf
- (/) C4, C5, C7 & C8 are 470pf
- (/) C9, C10, C12, C19 & C22 are .1uf
- (/) C14 is .15uf mylar
- (/) C15, C16 & C17 are .033uf
- (/) C0 is 500uf
- (/) C11 is 1uf
- (/) C13 is 35uf
- (/) C18 is 4.7uf

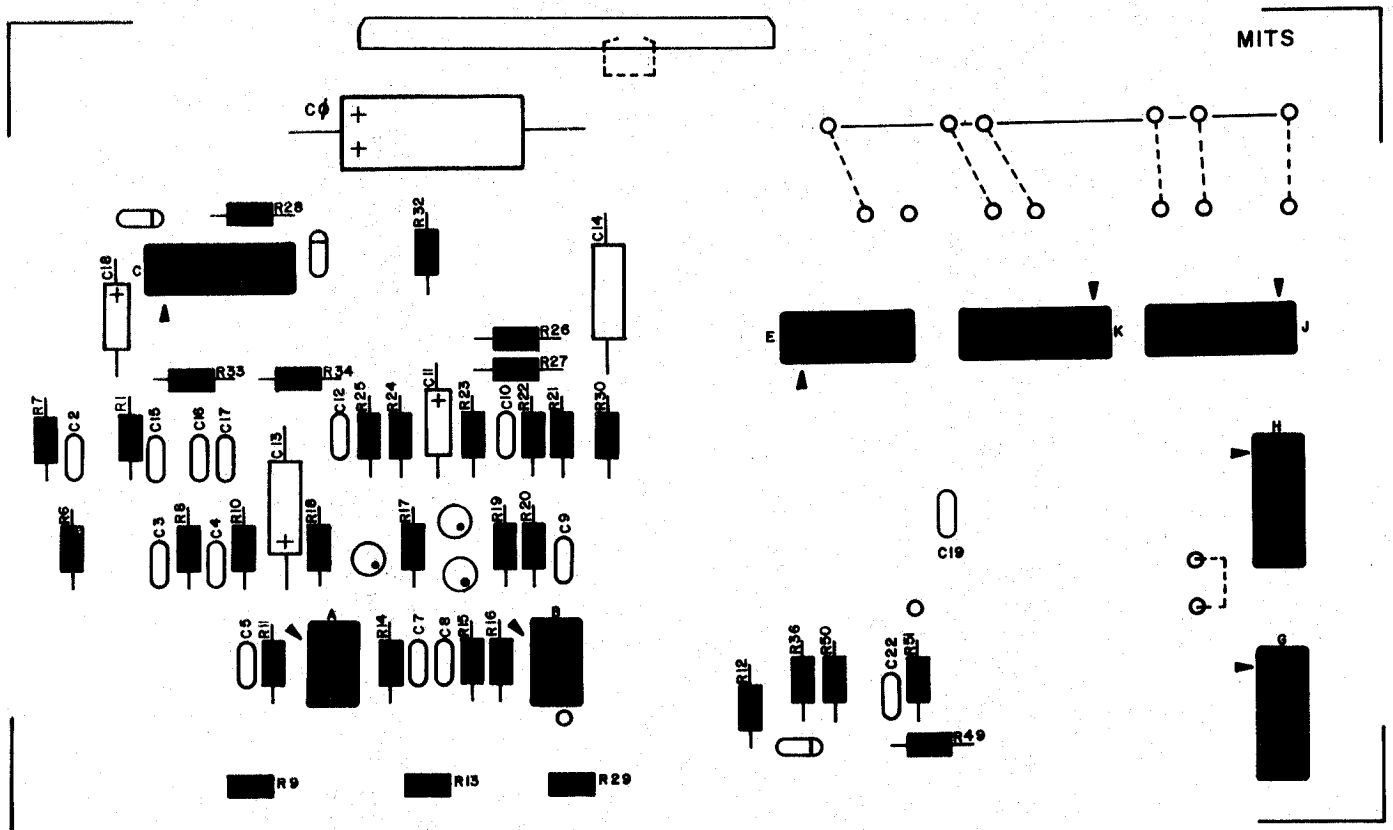

Diode Installation

There are two 1N914 diodes and one 12v zener diode to be installed on the 88-ACR Modem Board.

NOTE: Diodes are marked with a band on one end indicating the cathode end. The diode must be oriented so that the end with the band is towards the band printed on the board when being installed.

- (/) Referring to the component layout, bend the leads of zener diode Z1 at right angles to match the correct holes on the board.
- (/) Insert the diode into the correct holes from the silk-screened side of the board. Turn the board over and bend the two leads slightly outward.
- (/) Solder the two leads to the foil pattern on the back side of the board; then clip off any excess lead lengths.

Install 1N914 diodes D3 & D4 in the same manner. Be sure you have the correct orientation as you install each one.

() Z1 is a 12v zener (1N4742)

() D3 is a 1N914

() D4 is a 1N914

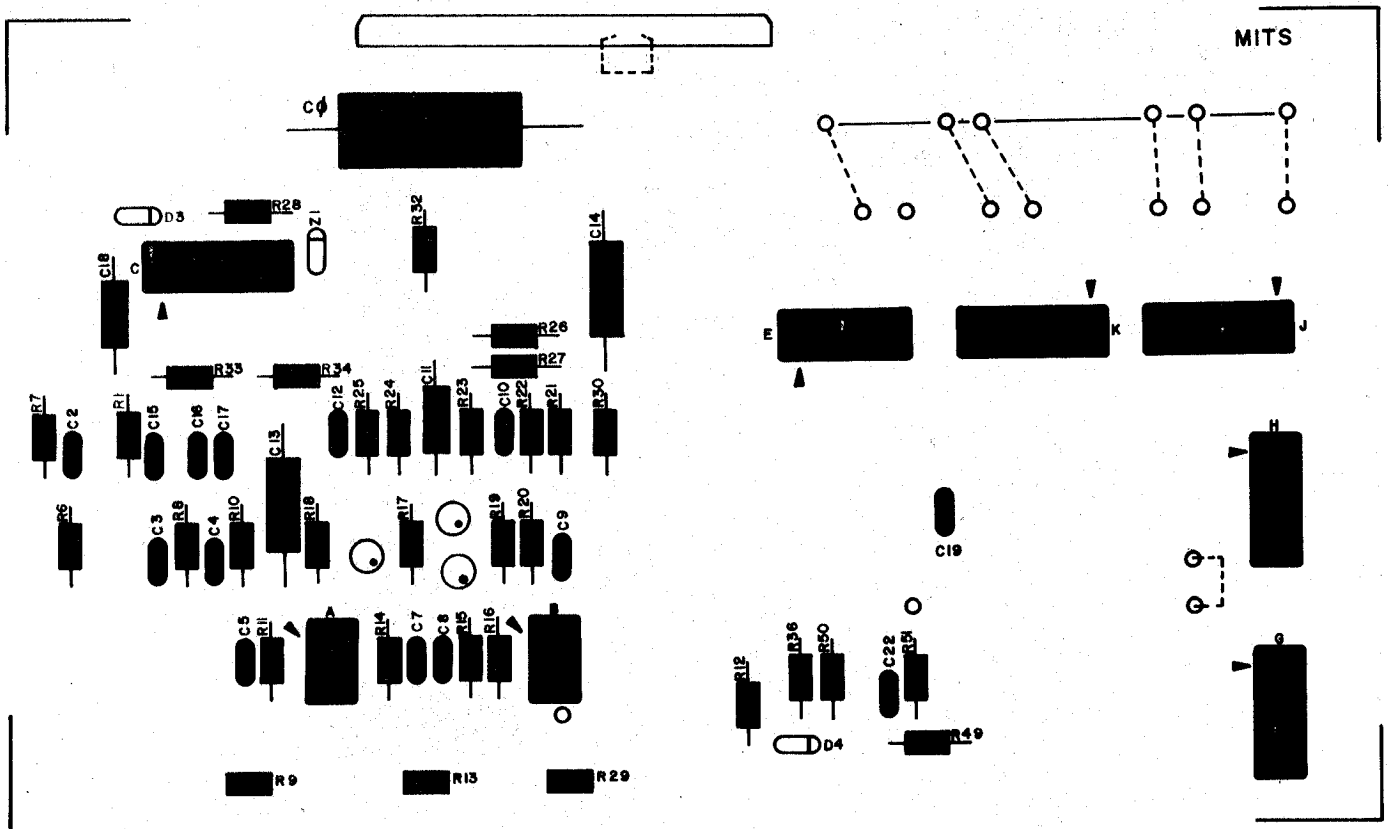

Transistor Installation

There are three transistors to be installed on the 88-ACR Modem Board, 1 NPN (CS4410) and 2 PNP (EN2907).

NOTE: When installing these transistors, ensure that you check the part numbers on them before soldering them into place. Some transistors are identical in physical appearance but differ in electrical characteristics. If the part numbers on your transistors do not match the numbers called for in the instructions, it may be that you have substitutions. In this case, refer to the Transistor Identification Chart included with your manual.

- (/) These transistors are rounded and have a flat edge near one of the leads. The lead nearest this flat edge is called the emitter. The hole for the emitter is the one marked with a dot and the letter "E" on the board. If the emitter lead is placed into this hole, the other two leads should fit into their holes with little or no bending and should not cross over each other. (see drawing below)

- (/) Orient transistor Q2 (EN2907) so that the lead nearest the flat edge aligns with the correct hole on the board. Insert the transistor into the holes from the silk-screened side of the board.
- (/) Holding the transistor in place, turn the board over and bend the three leads slightly outward.
- (/) Solder the leads to the foil pattern on the back side of the board; then clip off any excess lead lengths.

Referring to the component layout, install transistors Q3 & Q4 in the same manner. Be sure that you have the correct part number and the correct orientation for each one as you install them.

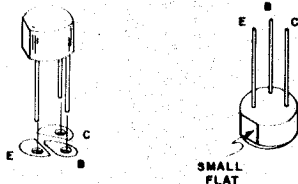

() Q2 is an EN2907

() Q3 is an EN2907

() Q4 is a CS4410

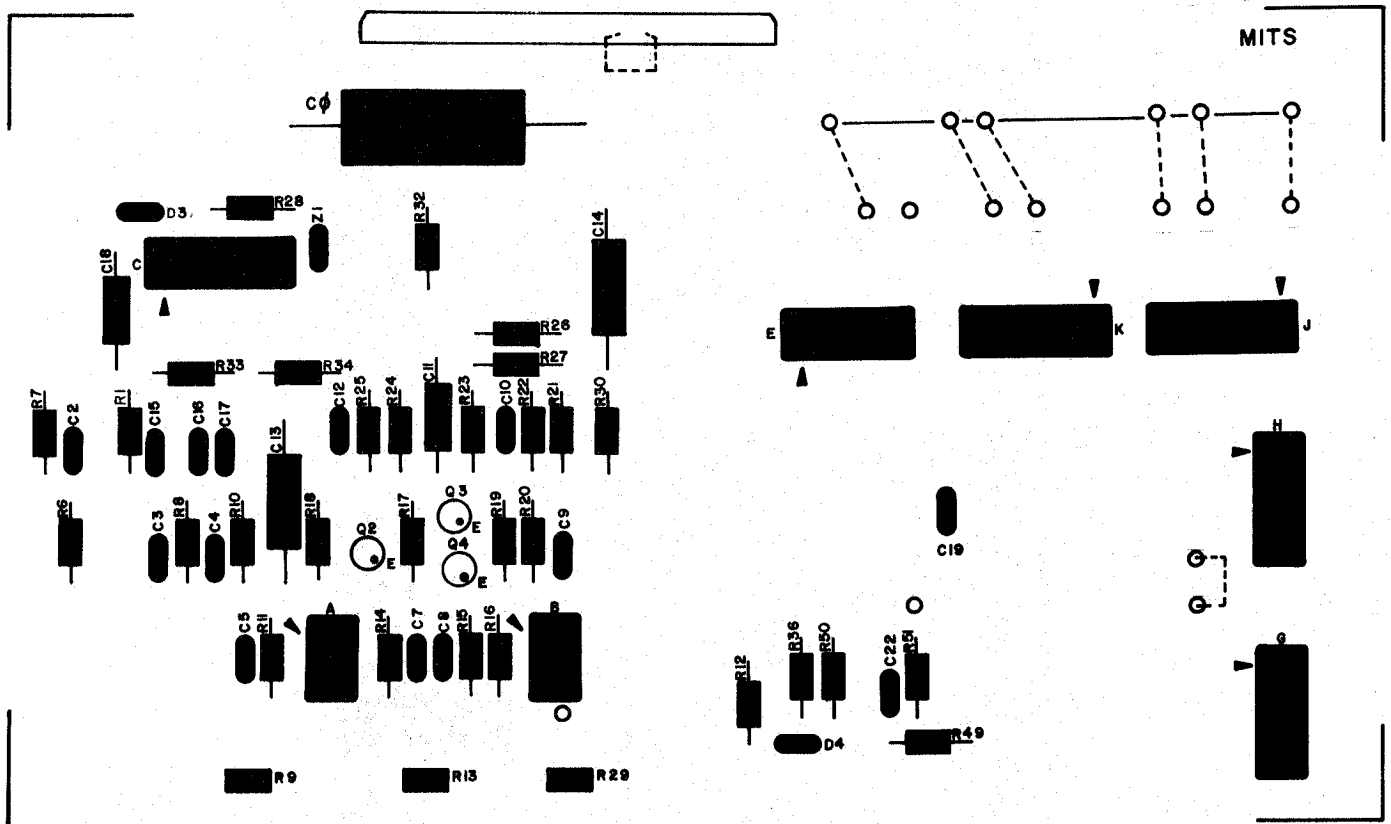

Hardwire Jumper Installation

There are 8 hardwire connections to be made directly on the 88-ACR Modem Board.

These connections are to be made using the 1 1/2 inch wires provided with your kit as follows:

- (1) Insert the jumper wires one at a time into the correct holes from the silk-screened side of the PC board.
- (2) Turn the board over and solder each of the leads to the foil pattern on the back side of the board. Clip off the excess wire lengths.

The positions on the board for the jumpers are indicated by two pads with a particular designation and connected by a broken line.
(see component layout)

(/) Connect A to K

(/) Connect J3 to J4

(/) Connect 1 to B

(/) Connect 2 to B

(/) Connect 3 to B

(/) Connect 4 to B

(/) Connect 5 to B

(/) Connect 7 to B

Note 6 is omitted

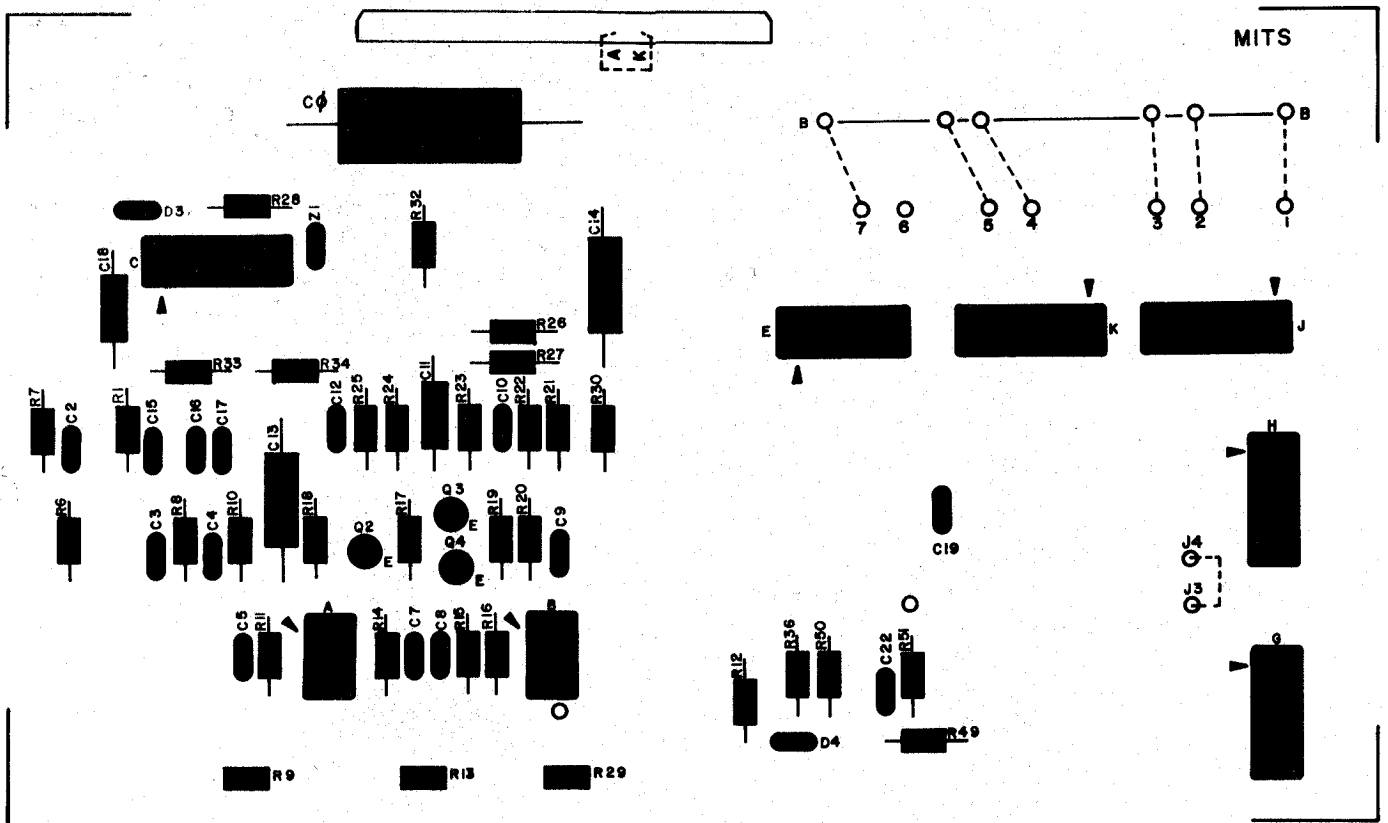

88-ACR Modem/SIO B Board Interface

There are 10 hardwire jumper connections to be made between the 88-ACR Modem Board and the Serial I/O B (TTL) Board.

Use the 8 inch wires provided with your kit to make all of these connections.

- () Orient the two boards in front of you with the silk-screened sides facing down. The edge connector contacts on the S I/O board should be touching the side of the Modem Board closest to capacitor C0.

The boards may be moved from this position in order to locate the connection points; but, this is the position to maintain the proper spacing for the wires when making the connections. All of the connections should be made from the nonsilk-screened sides of the boards.

Some of these connections will be made to the pins on the S I/O board wafer connector. These pins protrude slightly from the back side of the board and are fairly close together. Exercise great care when making these connections in order to prevent shorts between pins or between pins and PC lands.

Connect the following points on the two boards according to the instructions above:

- RECORD OUT (✓) "R0" on the Modem to the leftmost wafer connector pin (Spare) as viewed from the silk-screened side of the S I/O board.
- PLA IN (✓) "P/R" on the Modem to the second pin on the wafer connector (Spare) of the S I/O board.

SEE NOTES

- (✓) Connect separate wires to the two pads "GND" on the Modem and join the other ends together to the "GND" pad on the wafer connector of the S I/O board.
- (✓) In the same manner connect with 2 wires the pads "Vcc" on the Modem to the "+5V" pin of the connector on the S I/O board.
- (✓) "RS" on the Modem to "SRSI" on the wafer connector of the S I/O board.
- (✓) "XS" on the Modem to "STS0" on the wafer connector of the S I/O board.
- (✓) "F1" on the Modem to "S0" on the S I/O board (pad located between IC's Q & R)
- (✓) "-12V" on the Modem to -12v on the S I/O board. This pad may or may not be marked on the S I/O B board. It is located between C9 and IC K, and connects with the PC land which joins one end of R1 to the anode (non-banded) side of Z1.

Be sure to clip off any excess wire from the connections, and check over all of them on both boards to be sure there are no shorts or solder bridges.

88-ACR Modem/SIO B Board Mating

The 88-ACR Modem Board and the Serial I/O B Board must be mated together before installation to the ALTAIR.

The drawing on the opposite page shows the correct orientation for the two boards to be mated.

(✓) Using the hardware supplied with your kit, mount the two boards together as shown in the drawing.

It is very important that you use the exact orientation shown in the drawing for both the boards and the connecting hardware.

MATE THE TWO BOARDS AS SHOWN BELOW.

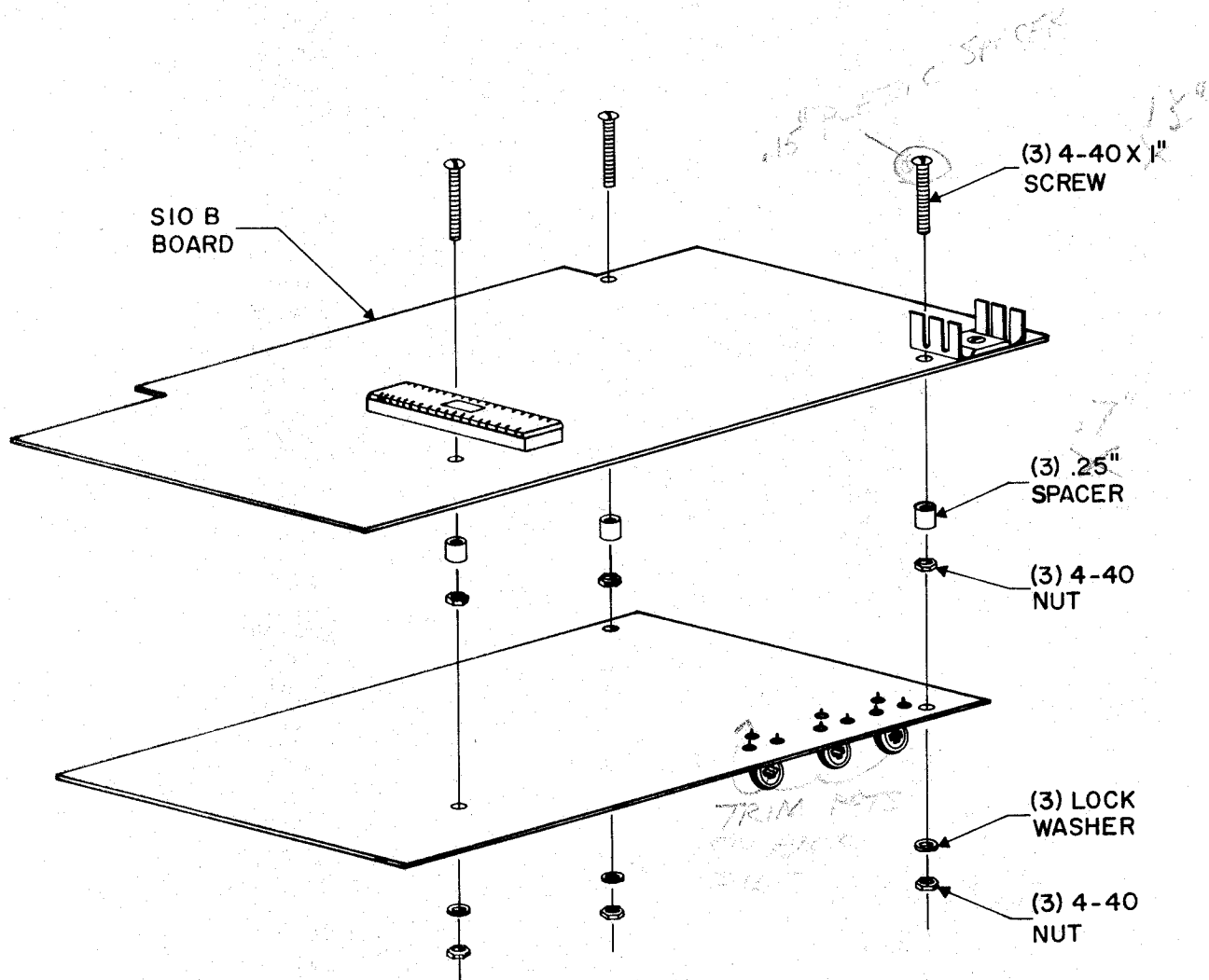

I/O Interface Cable Assembly

There are two 20 inch lengths of shielded cable provided with your kit.

- () Using a small sharp knife, strip 1 inch of the outer insulation from both ends of each of the two cables. Do this by cutting a small circle, 1 inch from the end, around the cable and pulling the insulation off. Save the pieces you pull off for later use.
- () Separate the shielding from the inner wire, and twist its strands together as tightly as possible on each end.
- () Again, using a small sharp knife, strip 1/8 inch of insulation from the ends of the inner wires of both cables.
- () Cut 2 pieces of the insulation saved earlier and place them over the shielding wire on one end of the two cables so that only 1/4 inch of bare wire protrudes. Place this end of the two cables together and twist the 2 1/4" sections of shielding into one wire.
- () Referring to page 15 of the S I/O B board assembly procedure, attach a connector pin to each of the three wires on the side of the cables where the shields are joined.
- () Referring to page 16 of the S I/O B board assembly procedure, insert the three connector pins into the female connector in the following locations:
 - The pin connected to the two shields goes to "GND",
 - The two pins connected to the two inner wires each go to one of the two "Spare" positions.

This connects the inner wire of one cable to "RO" on the Modem board, and the inner wire of the other to "P/R" on the Modem board.

- () Using a piece of masking tape, label the cable whose inner wire goes to the outside connector pin ("RO") with the words "Record Out". Label the other cable ("P/R") with the words "Play In".

There are two miniature phone jacks also included in your kit.

These jacks each have three solder terminals connected to them. You will observe one of the solder terminals to be connected directly to the center metal portion of the jack which runs through to the mounting threads.

- () Again, cut two pieces of the insulation saved earlier, and place them over the shielding on the two cables so that only 1/8 inch of bare shielding protrudes.
- () Solder the shielding on the two cables to the two jacks on the solder terminal described above.

There are two mechanical contacts on the jacks. One of these is squared, and the other is curved and on the inside position. By observing the jacks from the side, it may be seen that the center of the three solder terminals is connected to the curved contact.

- () Solder the inner wires of the two cables to the solder terminals described above on the two jacks.

Check the connections on both jacks to be sure there are no shorts and that the connections touch no other portion of the jacks but the solder terminals.

88-ACR & I/O Cable Installation

The two phone jacks can now be mounted onto the ALTAIR back panel.

There are two 1/4 inch holes near the bottom of the ALTAIR back panel, on the side opposite the transformers.

- () Using a piece of rough sandpaper or a small screwdriver blade, scrape the painted area around the two 1/4 inch holes on the inside of the case to expose the bare metal.
- () Remove the mounting hardware from the two phone jacks and place them into the 1/4 inch holes from the inside of the case.
- () Put the mounting hardware back onto the jacks and tighten them into place.

There are two foil labels included with your kit.

- () Remove the backing from the label "TAPE RECORD OUT" and place it over the jack, on the outside of the back panel, connected to the cable labeled "Record Out".
- () Remove the backing from the other label and place it over the other jack in the same manner.
- () Remove the tape labels from the two cables.
- () Attach the female connector on the opposite end of the two cables to the wafer connector on the SIO B board using the orientation described on the preceding page.

The 88-ACR may now be installed into the ALTAIR main case.

The unit should be installed using the edge connector contacts of the SIO B board, with the same general orientation as the other boards in your system. The components on the SIO B board should be facing towards the right side of the ALTAIR as viewed from the front. As this unit consists of two boards, it should be installed in the last slot available on the "mother board" in the system.

88-ACR Alignment Procedure

There are two methods listed for the alignment of the 88-ACR. If an oscilloscope is available, the first method should be used.

Alignment with an Oscilloscope

Read over the section in this manual on Using the 88-ACR; then record the "Output Test Program", listed on page 27, for approximately 15 minutes (one side of a C-30 cassette).

Once this is accomplished, rewind the tape and begin playing it back into the computer. For this purpose, no input program is necessary.

Place the oscilloscope to view the signal at the point labeled "TP" on the Modem board. The scope should be set at approximately 2v/div. vertically and 5ms/div. horizontally.

The point "TP" is the output of the two stage Op Amp filter. Reduce the volume on the recorder as necessary to give an unclipped output at this point.

Using an insulated alignment tool or insulated screwdriver, adjust the two trim pots located closest to the front panel (R9 & R13). Set them to give the maximum smooth output at "TP". It may be necessary to reduce the volume on the recorder during adjustment to prevent clipping of the signal.

If necessary rewind the tape and begin the program over. Set the tone and the volume controls of the recorder at maximum.

Set the oscilloscope to view the signal at "SRSI" on the connector on the SIO B board. Adjust the scope as necessary to view the following.

Trim pot R29 (closest to back panel) should now be adjusted for a +5 volt peak-to-peak square wave.

The signal should be symmetrical, high period = low period; and at a 300 BAUD setting it will be approximately 3.3ms per period (bit).

Alignment without an Oscilloscope

Read over the section in this manual on Using the 88-ACR; then record the "Output Test Program", listed on page 27, for approximately 15 minutes (one side of a C-30 cassette).

The two trim pots closest to the front panel (R9 & R13) should be placed in the center position of their full adjustment travel. These are the trim pots for the Op Amp filter and are not critical. They should be left in this position.

The "Input Test Program", listed on page 28, should now be loaded into the computer.

Once this is accomplished, begin playing the tape into the computer as described in the section on Using the 88-ACR.

With the system functioning normally, if trim pot R29 is not adjusted properly, address lights A0, A1 & A2 only will be lighted.

Using an insulated alignment tool or insulated screwdriver, slowly adjust R29 back and forth until all of the address lights A0 through A7 light, indicating the Test Word is being received properly.

There will be approximately 1/8 turn of travel where this occurs. Find the end points where the signal is lost and set the pot exactly in the center of this area of travel.

SERIAL I/O BOARD ASSEMBLY MANUAL ERRATA

THE FOLLOWING INFORMATION IS IN REFERENCE TO THE "HARDWIRE CONNECTIONS" SECTION OF THE I/O MANUAL (Page 12 in the SIO A & C, Page 10 in the SIO B).

THERE ARE FIVE PADS TO BE OPTIONALLY CONNECTED TO EITHER GROUND OR +V. THE DESIGNATIONS PRINTED ON THE BOARD, POE, NDB1, NDB2, NSB AND NPB, REFER TO THE ENTIRE HORIZONTAL GROUP OF THREE PADS TO THE RIGHT OF IC M. THE PADS CLOSEST TO IC M ARE THE ONES TO BE CONNECTED TO EITHER THE SECOND VERTICAL GROUP OF FIVE PADS (GND) OR THE THIRD VERTICAL GROUP OF FIVE PADS (+V). THE POE, NDB1, NDB2, NSB AND NPB PADS THEMSELVES ARE THE FIVE PADS RUNNING VERTICALLY DIRECTLY NEXT TO IC M.